

Scaler, supragingivaler Einsatz

Scalers, supragingival

Limpiadores de sarro, supragingival

Instruments à détartrer, supragingival

Ablatori di tartaro, supragingival

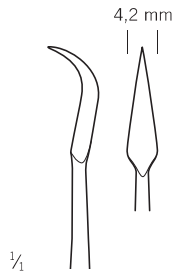

43-247-01-07
Fig. 1

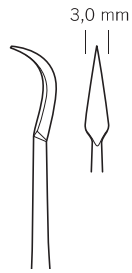

43-247-02-07
Fig. 2

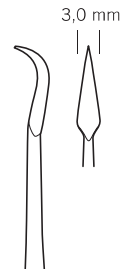

43-247-03-07
Fig. 3

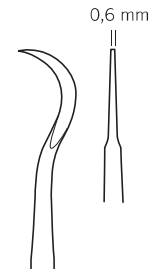

43-247-32-07
Fig. 32

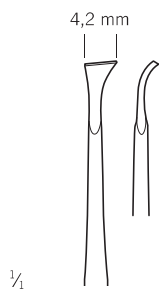

43-247-33-07
Fig. 33

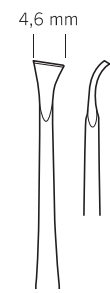

43-247-34-07
Fig. 34

43-247-01-07 -
43-247-36-07

17,5 cm / 6 7/8"

massiver Griff, 6 mm

solid handle, 6 mm

mango sólido, 6 mm

poignée massive, 6 mm

solida impugnatura, 6 mm

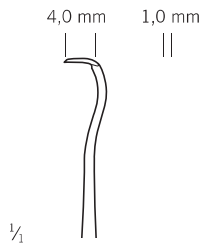
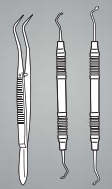

Jaquette
43-271-33-07
Fig. 33

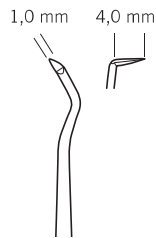

Jaquette
43-271-34-07
Fig. 34

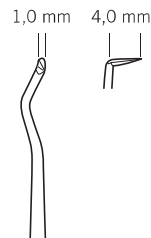

Jaquette
43-271-35-07
Fig. 35

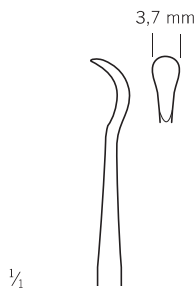

Cumine
43-282-04-07
Fig. 33

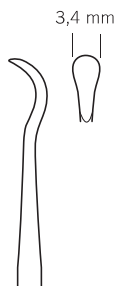

Mitchell
43-283-04-07
Fig. 34

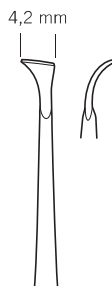

43-288-33-07
Fig. 33/34

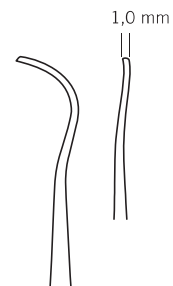

Younger-Good
43-291-07-07
Fig. 33/34

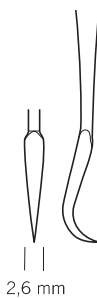

43-271-33-07 -
43-291-07-07

17,5 cm / 6 7/8"

massiver Griff, 6 mm

solid handle, 6 mm

mango sólido, 6 mm

poignée massive, 6 mm

solida impugnatura, 6 mm

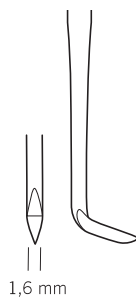

1,6 mm

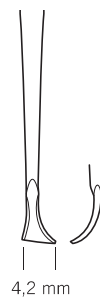

4,2 mm



1,0 mm

Scaler, supragingivaler Einsatz

Scalers, supragingival

Limpiadores de sarro, supragingival

Instruments à détartrer, supragingival

Ablatori di tartaro, supragingival



Towner
43-311-05-07
Fig. 5/33



Frontzähne, Prämolaren,
universell, auch approximal
Incisors, premolars,
universal, also approximal
Incisivos, premolares,
universal, también aproximal
Incisives, prémolaires,
universel, aussi approximal
Incisivi, premolari,
universali nonché contigui

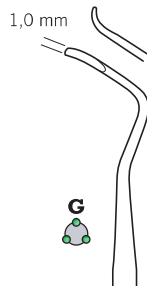

McCall
43-311-13-07
Fig. 13S/14S



Seitenzähne, mesial/distal
Besonders gut für Interdental-
räume im Molarenbereich
Lateral teeth, mesial/distal
Particularly useful for working in
interdental spaces in molar region
Dientes laterales, mesial/distal
Esp. indicado para espacios
interdentales en la región molar
Dents latérales, mésial/distal
Particulièrement adapté aux
espaces interdentaires dans zone
molaire
Denti laterali, mesial/distali
Particolarmente adatto agli spazi
interdentali nel regione molare



McCall
43-311-14-07
Fig. 13SM/14



Seitenzähne, mesial / distal,
wie 13S/14S mit abgerundeter
Spitze
Lateral teeth; mesial/distal,
like 13S/14S, with rounded tip
Dientes laterales, mesial/ distal,
como 13S/14S, pero con punta
redondeada
Dents latérales, mésial/distal,
comme 13S/14S avec pointe
arrondie
Denti laterali, mesial/distali,
come 13S/14S con punta
arrotondata

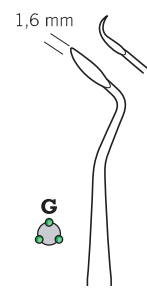

Taylor
43-311-15-07
Fig. T 2/3



Frontzähne, Prämolaren,
Molaren, universell
Besonders gut für Interdental-
räume im Molarenbereich
Incisors, premolars, molars,
universal
Particularly useful for working
in interdental spaces in molar
region
Incisivos, premolares, molares,
universal
Esp. indicado para espacios
interdentales en la región molar
Incisives, prémolaires, molaires,
universel
Particulièrement adapté aux
espaces interdentaires dans zone
molaire
Incisivi, premolari, molari,
universali
Particolarmente adatto agli spazi
interdentali nel regione molare

43-311-05-07 -
43-311-15-07

17,5 cm / 6 7/8"

Hohlgriff, 8 mm
hollow handle, 8 mm
mango hueco, 8 mm
poignée creuse, 8 mm
manico cavo, 8 mm

GR = grau
grey
gris
gris
grigio

Y = gelb
yellow
amarillo
jaune
giallo

R = rot
red
rojo
rouge
rosso

G = grün
green
verde
vert
verde

V = violett
violet
violeta
violet
viola

W = weiß
white
blanco
blanc
bianco

B = blau
blue
azur
bleu
blu

N = schwarz
black
negro
noir
nero

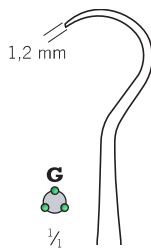
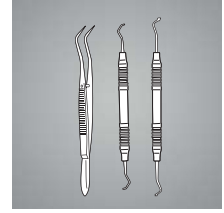

Towner
43-311-16-07
Fig. 15/30



Zum Entfernen von hartnäckigem Zahnstein
For removing stubborn tartar/scale
Para quitar sarro y cálculo persistentes
Pour enlever la tartre dentaire tenace
Per la rimozione di tartaro persistente

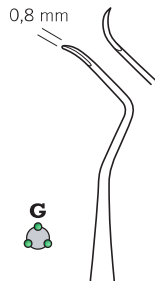

43-311-17-07
Fig. U 135



sehr schwer zugängliche Approximalflächen
for hard-to-access approximal surfaces
para superficies aproximales poco accesibles
pour surfaces proximales d'accès très difficile
per superfici contigue difficilmente accessibili

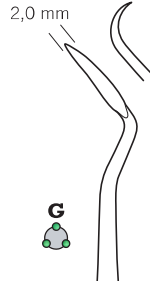

43-311-18-07
Fig. Cl 2/3



Frontzähne, Prämolaren, Molaren, universell
Incisors, premolars, molars, universal
Incisivos, premolares, molares, universal
Incisives, prémolaires, molaires, universel
Incisivi, premolari, molari, universali

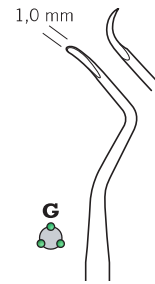

43-311-19-07
Fig. M 23



Frontzähne, Prämolaren, mesial/distal
Incisors, premolars, mesial/distal
Incisivos, premolares, mesial/distal
Incisives, prémolaires, mésial/distal
Incisivi, premolari, mesiali/distali

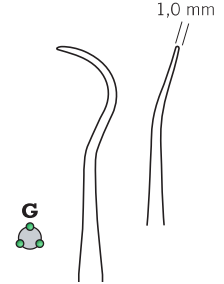

Mc Call
43-784-18-07
Fig. 17/18



Universal
universal
universal
universel
universale

43-311-16-07 -
43-784-18-07

17,5 cm / 6 7/8"

Hohlgriff, 8 mm
hollow handle, 8 mm
mango hueco, 8 mm
poignée creuse, 8 mm
manico cavo, 8 mm

Scaler, supragingivaler Einsatz

Scalers, supragingival

Limpiadores de sarro, supragingival

Instruments à détartrer, supragingival

Ablatori di tartaro, supragingival



1/4

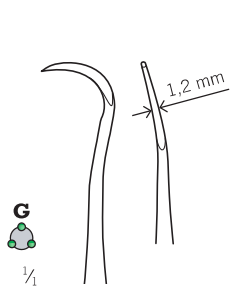

G
Hygienist
43-312-06-07
Fig. H6/H7

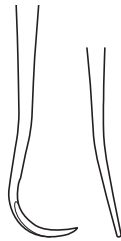

Frontzähne, Prämolaren,
mesial/distal
Besonders gut im
Interdentalraum
Incisors, premolars,
mesial/distal
Particularly useful for
interdental spaces

Incisivos, premolares,
mesial/distal
Esp. indicado para los
espacios interdentes

Incisives, prémolaires,
mésial/distal
Particulièrement adapté aux
espaces inter-dentaires

Incisivi, premolari,
mesiali/distali
Particolarmente adatto agli
spazi interdentali

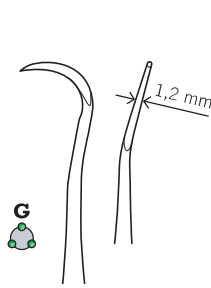

G
Hygienist
43-312-10-07
Fig. H6/H7



Frontzähne, Prämolaren,
mesial/distal
Besonders gut im
Interdentalraum
Incisors, premolars,
mesial/distal
Particularly useful for
interdental spaces

Incisivos, premolares,
mesial/distal
Esp. indicado para los
espacios interdentes

Incisives, prémolaires,
mésial/distal
Particulièrement adapté aux
espaces inter-dentaires

Incisivi, premolari,
mesiali/distali
Particolarmente adatto agli
spazi interdentali



G
43-314-00-07
Fig. 204



Molaren, universell
Molars, universal
Molares, universal
Molaires, universel
Molari, universale



G
43-314-01-07
Fig. 204 S



Molaren, universell
Molars, universal
Molares, universal
Molaires, universel
Molari, universale



G
43-314-02-07
Fig. 204 SD



Frontzähne, Prämolaren,
mesial/distal

Incisors, premolars,
mesial/distal

Incisivos, premolares,
mesial/distal

Incisives, prémolaires,
mésial/distal

Incisivi, premolari,
mesiali/distali

43-312-06-07 -
43-314-02-07
17,5 cm / 6 3/4"

Hohlgriff, 8 mm
hollow handle, 8 mm
mango hueco, 8 mm
poignée creuse, 8 mm
manico cavo, 8 mm

GR = grau
grey
gris
gris
grigio

Y = gelb
yellow
amarillo
jaune
giallo

R = rot
red
rojo
rouge
rosso

G = grün
green
verde
vert
verde

V = violett
violet
violeta
violet
viola

W = weiß
white
blanco
blanc
bianco

B = blau
blue
azur
bleu
blu

N = schwarz
black
negro
noir
nero

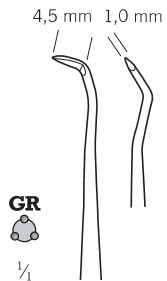
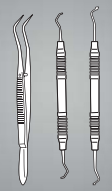

Zürich
43-318-04-07

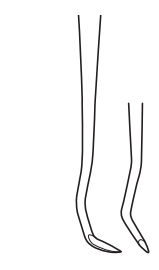

Reinigen von Kavitäten nach WSR

For cleaning cavities following apicoectomy

Para limpiar cavidades después de la apicectomía

Pour nettoyer les cavités après la résection de l'apex

Per la pulizia delle cavità in seguito a interventi di apicectomia

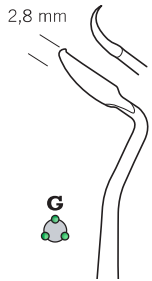

43-321-06-07
Fig. CC 6

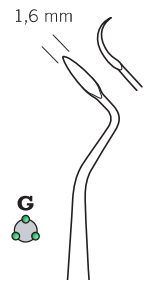

43-321-23-07
Fig. T 2/3



Frontzähne, Prämolaren, Molaren, universell

Incisors, premolars, molars, universal

Incisivos, premolares, molares, universal

Incisives, prémolaires, molaires, universel

Incisivi, premolari, molari, universali

43-318-04-07 -
43-321-23-07
17,5 cm / 6 3/4"
Hohlgriff, 8 mm
hollow handle, 8 mm
mango hueco, 8 mm
poignée creuse, 8 mm
manico cavo, 8 mm

Scaler, supragingivaler Einsatz

Scalers, supragingival

Limpiadores de sarro, supragingival

Instruments à détartrer, supragingival

Ablatori di tartaro, supragingival

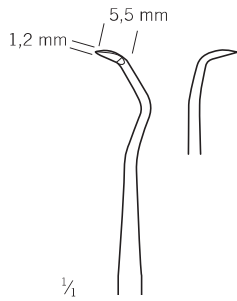

Jaquette
43-323-32-07
Fig. 31/32

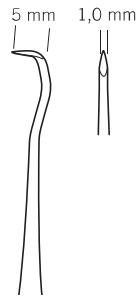

Jaquette
43-323-33-07
Fig. 30/33

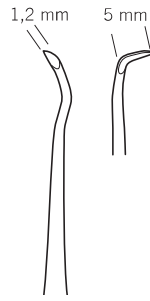

Jaquette
43-323-35-07
Fig. 34/35



43-323-32-07 -
43-323-35-07

17,5 cm / 6 7/8"

Hohlgriff, 8 mm
hollow handle, 8 mm
mango hueco, 8 mm
poignée creuse, 8 mm
manico cavo, 8 mm

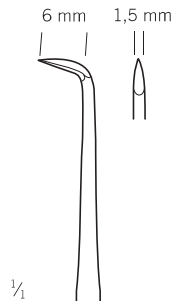
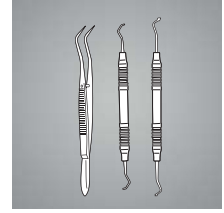

Goldman-Fox
43-326-31-07
Fig. 1

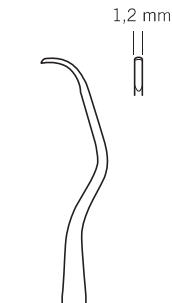

Goldman-Fox
43-326-32-07
Fig. 2

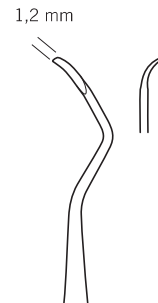

Goldman-Fox
43-326-33-07
Fig. 3

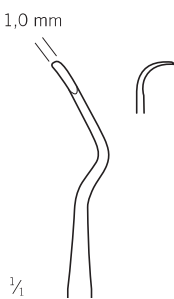

Goldman-Fox
43-326-34-07
Fig. 4

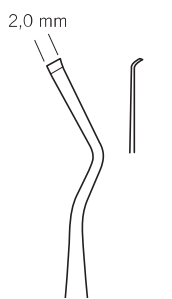

Goldman-Fox
43-326-35-07
Fig. 5

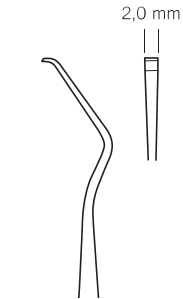

Goldman-Fox
43-326-36-07
Fig. 6



43-326-31-07 -
43-326-36-07

17,5 cm / 6 7/8"

Hohlgriff, 8 mm
hollow handle, 8 mm
mango hueco, 8 mm
poignée creuse, 8 mm
manico cavo, 8 mm

Scaler, supragingivaler Einsatz, Knochenfeilen

Scalers, supragingival, bone files

Limpiadores de sarro, supragingival, limas de hueso

Instruments à détartrer, supragingival, râpes à os

Ablatori di tartaro, supragingival, lime e raspe per osso



1/4



1/4

Hirschfeld
43-315-03-07
Fig. 3/7



Hirschfeld
43-315-05-07
Fig. 5/11



Feile
File
Lima
Lime
Lima

Zur Entfernung von granulomatösem Gewebe aus supra- und infraosären Taschen

For removal of granulosomatous tissue from supra- and infrabone pockets

Para quitar el tejido de granulación en las bolsas supra-alveolares e intra-alveolares

Pour enlever le tissu granulomateux de poches supraosseuses et infraosseuses

Per la rimozione di tessuto granulomatoso di tasche sopraossee e infraossee

43-315-03-07 -
43-315-05-07

17,5 cm / 6 7/8"

Hohlgriff, 8 mm
hollow handle, 8 mm
mango hueco, 8 mm
poignée creuse, 8 mm
manico cavo, 8 mm



1/4

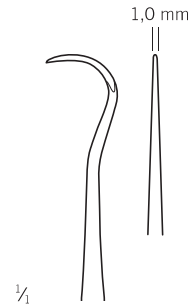

1/4

Mercitan
43-328-05-07
Fig. SH 5

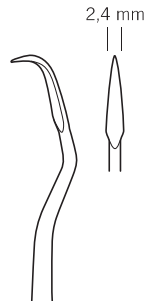

Ward-Kirkland
43-330-10-07
Fig. 1



1/4

Crane-Kaplan
43-330-20-07
Fig. 2

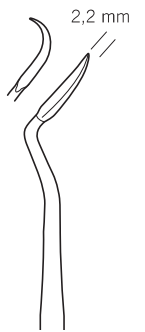

Crane-Kaplan
43-330-30-07
Fig. 3



1/4

White
43-358-12-07
Fig. 12B

43-328-05-07 -
43-358-12-07

17,5 cm / 6 7/8"

massiver Griff, 6 mm
solid handle, 6 mm
mango sólido, 6 mm
poignée massive, 6 mm
solida impugnatura, 6 mm

Parodontalfeile

Periodontal file
Lima parodontal
Lime parodontale
Lima periodontale

Parodontologie

Periodontology
Parodontología
Parodontologie
Parodontologia

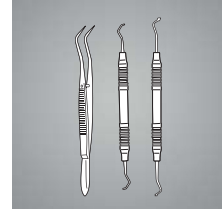

43

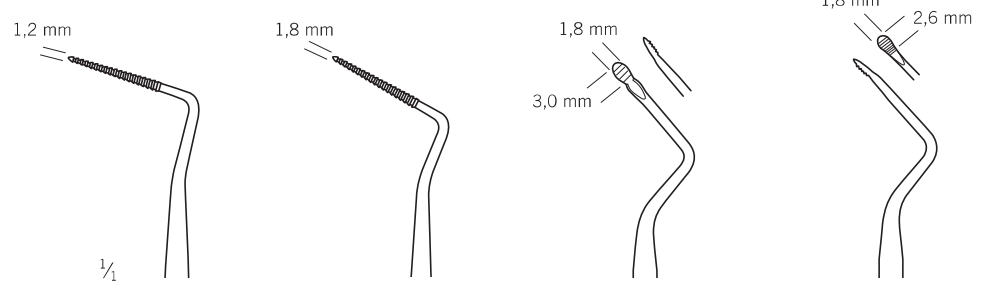

43-893-01-07 43-893-02-07 Orban 43-893-06-07 43-893-08-07
Fig. 12/13 Fig. 12/12

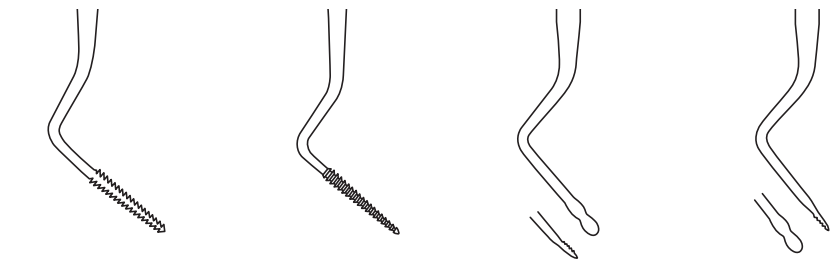

modifiziert
modified
modificado
modifié
modificato

43-893-01-07 -
43-893-08-07

17,5 cm / 6 7/8"
Hohlgriff, 8 mm
hollow handle, 8 mm
mango hueco, 8 mm
poignée creuse, 8 mm
manico cavo, 8 mm

Zur Entfernung von granulomatösem Gewebe aus supra- und infraossären Taschen
For removal of granulomatous tissue from supra- and infrabone pockets
Para quitar el tejido de granulación en las bolsas supra-alveolares e intra-alveolares
Pour enlever le tissu granuleux de poches supraosseuses et infraosseuses
Per la rimozione di tessuto granulomatoso di tasche sopraossee e infraossee

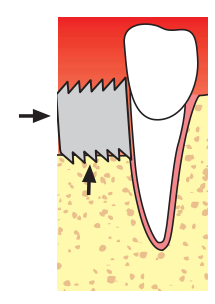

Parodontalfeile

Periodontal file

Lima parodontal

Lime parodontale

Lima periodontale



Roncati
43-810-00-07

17,5 cm / 6 7/8"

Hohlgriff, 10 mm
hollow handle, 10 mm
mango hueco, 10 mm
poignée creuse, 10 mm
manico cavo, 10 mm

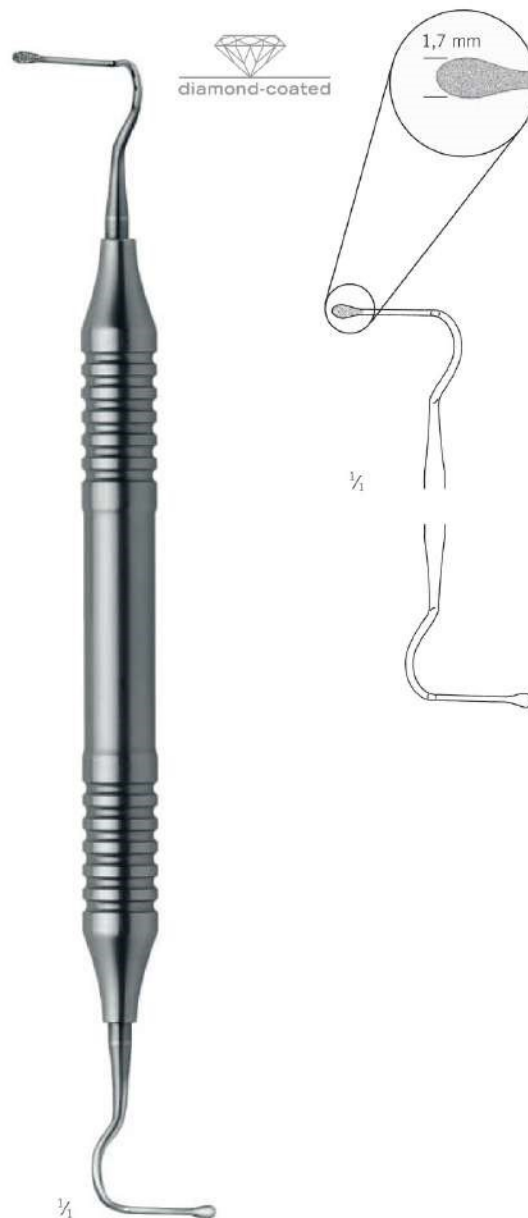

Roncati
43-810-01-07

17,5 cm / 6 7/8"

Hohlgriff, 10 mm
hollow handle, 10 mm
mango hueco, 10 mm
poignée creuse, 10 mm
manico cavo, 10 mm

Parodontalmeißel

Periodontal chisels
Cinceles de periodoncia
Burins de parodontie
Sgorbie per parodontologia

Parodontologie

Periodontology
Parodontología
Parodontologie
Parodontologia

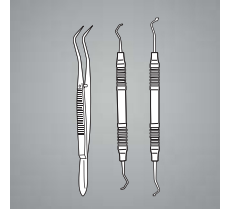

43

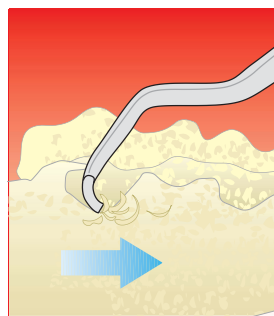
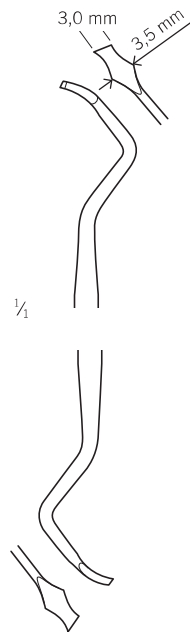

Mini-Meißel
Mini chisel
Mini cincel
Mini burin
Mini scalpello

Rhodes
43-363-01-07

Fig. 36/37

17,5 cm / 6 7/8"

Hohlgriff, 8 mm
hollow handle, 8 mm
mango hueco, 8 mm
poignée creuse, 8 mm
manico cavo, 8 mm

Parodontalmeißel

Periodontal chisels
Cinceles de periodoncia
Burins de parodontie
Sgorbie per parodontologia

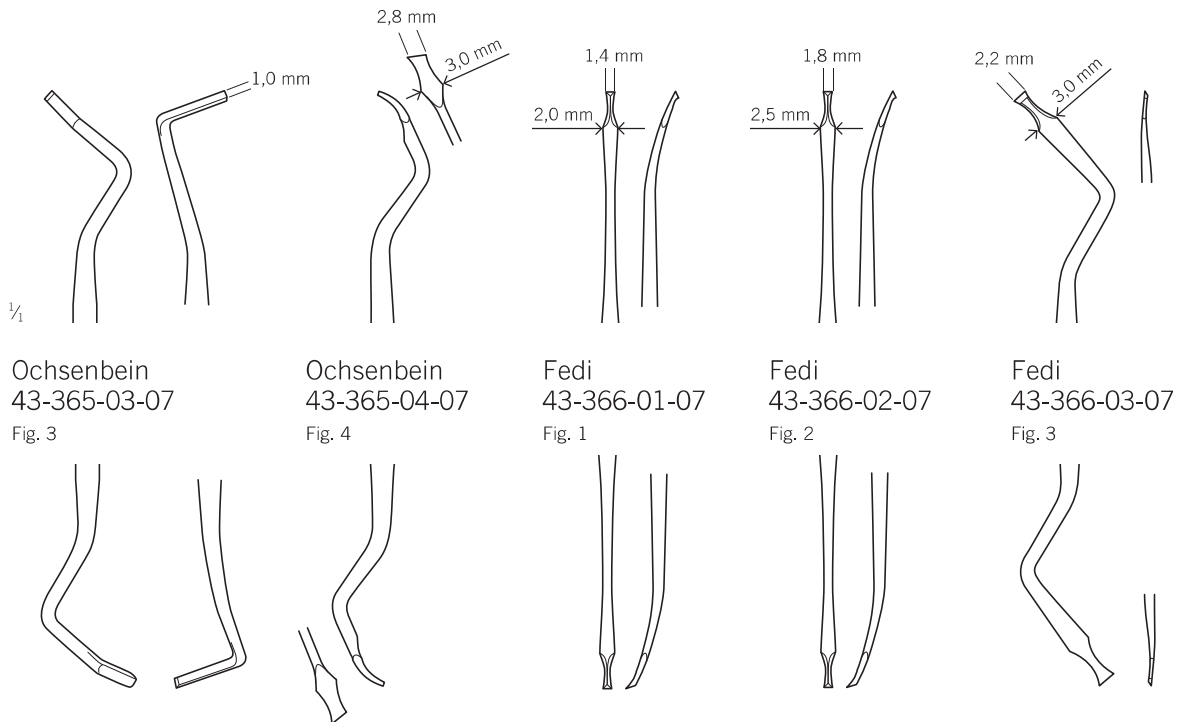

Für Lappenoperationen. Auch für kleinere Knochenkorrekturen
For flap operation. Also for minor bone corrections
Para operaciones de colgajo y correcciones óseas menores
Pour les opérations sur les lambeaux. Aussi pour corrections des os minimes
Per operazioni sui lembi. Anche per correzioni ossee minori

43-365-03-07 -
43-366-03-07

17,5 cm / 6 7/8"

Hohlgriff, 8 mm
hollow handle, 8 mm
mango hueco, 8 mm
poignée creuse, 8 mm
manico cavo, 8 mm

Küretten, subgingivaler Einsatz

Curettes, subgingival
Curetas, subgingival
Curettes, subgingival
Curette, subgingivale

Parodontologie

Periodontology
Parodontología
Parodontologie
Parodontologia

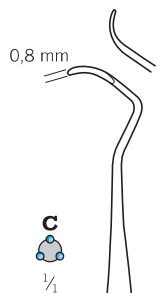
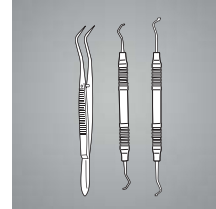

Columbia
43-290-13-07
Fig. 13/14



Front- und Seitenzähne, universell
Incisors and lateral teeth, universal
Incisivos y dientes laterales, universal
Incisives et dents latérales, universel
Incisivi e denti laterali, universali

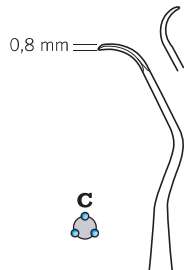

Columbia
43-290-20-07
Fig. 2R/2L



Frontzähne, universell
Incisors, universal
Incisivos, universal
Incisives, universal
Incisivi, universali

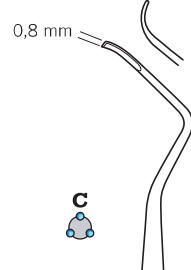

Columbia
43-290-40-07
Fig. 4R/4L



Seitenzähne, universell
Lateral teeth, universal
Dientes laterales, universal
Dents latérales, universel
Denti laterali, universali

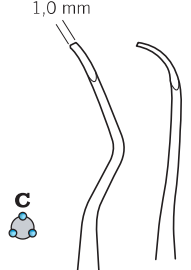

43-292-02-04
Fig. GX4



Front- und Seitenzähne, universell
Incisors and lateral teeth, universal
Incisivos y dientes laterales, universal
Incisives et dents latérales, universel
Incisivi e denti laterali, universali

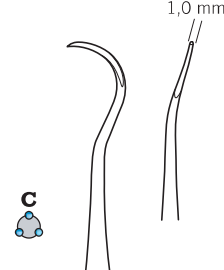

Mc Call
43-784-02-04
Fig. 17S/18S



Universal bifurkale Wurzelflächen
universal bifurcate root surfaces
universal superficies radiculares bifurcadas
universel surface de racine bifurcale
universali superfici di radici biforcute

43-290-13-07 -
43-784-02-07-

17,5 cm / 6 7/8"
Universalkürette
Universal curette
Cureta universal
Curette universelle
Curetta universale
Hohlgriff, 8 mm
hollow handle, 8 mm
mango hueco, 8 mm
poignée creuse, 8 mm
manico cavo, 8 mm

- GR** = grau
grey
gris
gris
grigio
- Y** = gelb
yellow
amarillo
jaune
giallo
- R** = rot
red
rojo
rouge
rosso
- G** = grün
green
verde
vert
verde
- V** = violett
violet
violeta
violet
viola
- W** = weiß
white
blanco
blanc
bianco
- B** = blau
blue
azur
bleu
blu
- C** = hellblau
light-blue
azul claro
bleu clair
azzurro

Küretten, subgingivaler Einsatz

Curettes, subgingival

Curetas, subgingival

Curettes, subgingival

Curette, subgingivale

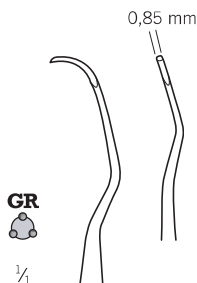

| Langer | |
|--------|--------------|
| St | 43-293-02-07 |
| Ti | 43-294-02-09 |

Fig. 1/2

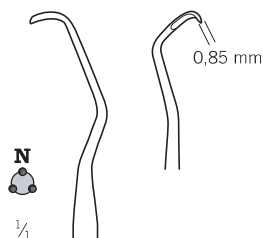

| Langer | |
|--------|--------------|
| | 43-293-04-07 |
| | 43-294-04-09 |

Fig. 3/4



| Langer | |
|--------|--------------|
| | 43-293-06-07 |
| | 43-294-06-09 |

Fig. 5/6



Unterkiefer,
Seitenzahnbereich,
mesial / distal
Mandible, lateral teeth,
mesial / distal
Maxilar inferior,
región dientes laterales,
mesial / distal
Mandibule, zone
des dents latérales,
mésial / distal
Mascella inferiore,
settore dei denti laterali,
mesiali / distali

Oberkiefer, Seitenzahnbereich,
mesial / distal
Maxilla, lateral teeth,
mesial / distal
Maxilar superior,
región dientes laterales,
mesial / distal
Maxillaire, zone
des dents latérales,
mésial / distal
Mascella superiore,
settore dei denti laterali,
mesiali / distali

Ober- und Unterkiefer,
Frontzähne, universell
Maxilla and mandible,
incisors, universal
Ambos maxilares,
incisivos, universal
Mandibule et maxillaire,
incisives, universel
Mascella superiore e inferiore,
incisivi, universali

Langer
43-293-02-07 -
43-294-06-09

17,5 cm / 6 7/8"

Universalkürette
Universal curette
Cureta universal
Curette universelle
Curetta universale

Hohlgriff, 8 mm
hollow handle, 8 mm
mango hueco, 8 mm
poignée creuse, 8 mm
manico cavo, 8 mm

GR = grau
grey
gris
gris
grigio

Y = gelb
yellow
amarillo
jaune
giallo

R = rot
red
rojo
rouge
rosso

G = grün
green
verde
vert
verde

V = violett
violet
violeta
violet
viola

W = weiß
white
blanco
blanc
bianco

B = blau
blue
azul
bleu
blu

N = schwarz
black
negro
noir
nero



Roncati Scaler
43-800-00-07
17,5 cm / 6 7/8"
H6/H7
Scaler
Scaler
Limpiador
Tartre
Ablatore di tartaro
Hohlgriff, 10 mm
hollow handle, 10 mm
mango hueco, 10 mm
poignée creuse, 10 mm
manico cavo, 10 mm



Roncati
43-800-01-07
17,5 cm / 6 7/8"
Kürette, mikro, gerade
Curette, micro, straight
Cureta, micro, recto
Curette, micro, droit
Curetta, micro, dritto
Hohlgriff, 10 mm
hollow handle, 10 mm
mango hueco, 10 mm
poignée creuse, 10 mm
manico cavo, 10 mm



Roncati
43-800-02-07
17,5 cm / 6 7/8"
Kürette, mikro, gebogen
Curette, micro, curved
Cureta, micro, curva
Curette, micro, courbe
Curetta, micro, curva
Hohlgriff, 10 mm
hollow handle, 10 mm
mango hueco, 10 mm
poignée creuse, 10 mm
manico cavo, 10 mm



Roncati
43-850-00-07 Ti
17,5 cm / 6 7/8"
Kürette, mikro, gebogen
Curette, micro, curved
Cureta, micro, curva
Curette, micro, courbe
Curetta, micro, curva
Hohlgriff, 10 mm
hollow handle, 10 mm
mango hueco, 10 mm
poignée creuse, 10 mm
manico cavo, 10 mm

Warum Scaling-Instrumente immer scharf sein sollten:

1. Scharfe Instrumente bedeuten exaktes Arbeiten bei geringem Kraftaufwand.
2. Stumpfe Instrumente polieren den Zahnstein, quetschen das Weichgewebe und erfordern einen erhöhten Kraftaufwand.

Was benötigt man zum Schleifen von Instrumenten:

1. Schleifsteine (grob, fein und rund zum Entgraten)
2. Schleiföl (verhindert zu hohe Hitzeentwicklung, Erhaltung der Schleifwirkung des Schleifsteines)
3. Teststäbchen (aus Acryl zur Schärfeprüfung)
4. gutes Licht (scharfe Kanten reflektieren kein Licht)
5. Spannvorrichtung (z.B. Schraubstock)

Was ist nach dem Schleifen zu überprüfen:

1. abgerundete Rückenflächen
2. durchgängig scharfe Schneidkanten
3. einwandfreie Form des Arbeitsendes (z.B. Vergleich mit Katalogabbildung)
4. nach mehmaligem Aufschleifen des Instruments ist darauf zu achten, dass das Instrument noch stabil genug ist, um bei der anschließenden Behandlung nicht zu brechen. Sonst sollte das Instrument durch ein neues ersetzt werden.

Why scaling instruments should always be sharp:

1. Sharp instruments allow precision work with little application of force.
2. Blunt instruments polish the dental stone, bruise the soft tissue and require more application of force.

What you need for instrument sharpening:

1. Sharpening stones (rough, fine, and round for burr removal)
2. Sharpening oil (prevents excessive heat build-up; preserves the sharpening capacity of the sharpening stone)
3. Test stick (made of acrylic, for sharpness test)
4. Good light (sharp edges do not reflect light)
5. Clamping device (e.g. vise)

What to check after sharpening:

1. Roundness of back surfaces
2. Continuous sharpness of cutting edges
3. Perfect shape of working end (e.g. check against catalog illustration)
4. After several sharpening cycles, verify that the instrument is still strong enough for application. Replace instrument if necessary.

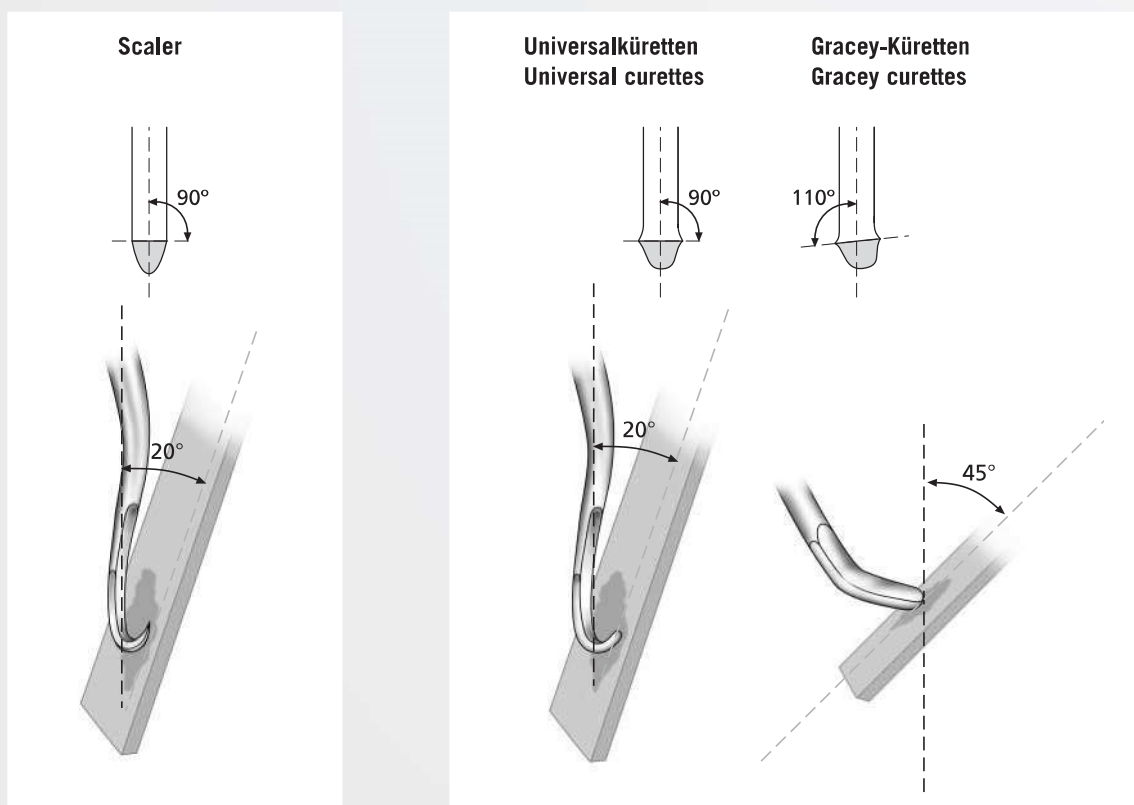

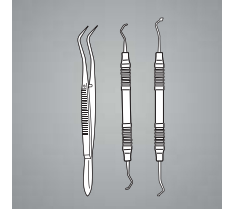

Farbkodierung von Scalern und Gracey-Küretten

1. Alle Scaler tragen eine grüne Farbkodierung – 3 Punkte verteilt auf den Durchmesser. Die Position der Farbkodierung kennzeichnet gleichzeitig das niedriger bezeichnete Arbeitsende.
2. Gracey Standard, Gracey Rigid und Gracey Mini Küretten tragen die Farbkodierung ebenfalls auf der Seite des niedriger bezeichneten Arbeitsendes, z.B. Gracey 1/2 = Farbkodierung auf der Seite von Arbeitsende Nr. 1.
3. Zur noch besseren Unterscheidung zwischen Gracey Standard und Gracey Mini auf der einen und Gracey Rigid auf der anderen Seite wurde bei den Gracey Rigid eine Farbkodierung mit sechs Farbpunkten gewählt.
4. Gracey Standard-Küretten mit Farbkodierung sind auch mit einem 10 mm-Griff erhältlich.

Color coding of scalers and Gracey curettes

1. All scalers are color-coded green – 3 points distributed across the diameter. At the same time, the color code marks the finer working end.
2. The Gracey Standard, Gracey Rigid and Gracey Mini curettes also have the color code on the side of the finer working end. Example: Gracey 1/2 = color code applied on side of working end no. 1.
3. For even better differentiation between Gracey Standard and Gracey Mini on the one hand and Gracey Rigid on the other hand, Gracey Rigid curettes are coded with six color points.
4. Color-coded Gracey Standard curettes are also available with a 10 mm handle.

43

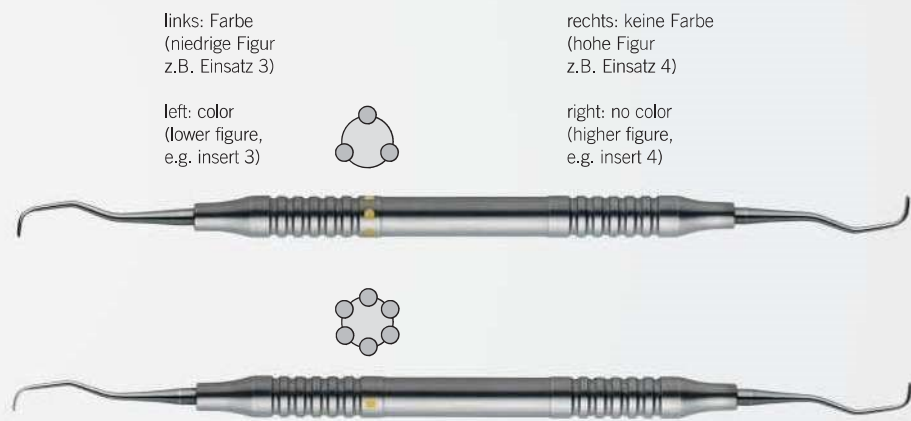

| | ∅ | | |
|-----------------|-------|---|---|
| Gracey Mini | 8 mm | x | |
| Gracey Standard | 8 mm | x | |
| Gracey Big | 10 mm | x | |
| Gracey Rigid | 8 mm | | x |



Anwendungsbereiche von Gracey-Küretten

Fields of application for Gracey curettes

- 1-2,3-4, 5-6 Frontzähne Incisors
- 7-8, 9-10 Prämolaren und Molaren (bukkal/lingual) Premolars and molars (buccal/lingual)
- 11-12, 15-16 Prämolaren und Molaren mesial, Furkation: mesialer Anteil der distalen Wurzel Premolars and molars, mesial Furcation: mesial portion of the distal root
- 13-14, 17-18 Prämolaren und Molaren distal, Furkation: distaler Anteil der mesialen Wurzel Premolars and molars, distal Furcation: distal portion of the mesial root

Gracey Mini-Küretten, subgingivaler Einsatz

Gracey mini curettes, subgingival

Gracey mini curetas, subgingival

Gracey mini curettes, subgingival

Gracey mini curette, subgingivale



1/4

Gracey Mini
43-336-02-07 -
43-336-18-07

17,5 cm / 6 7/8"

Hohlgriff, 8 mm
hollow handle, 8 mm
mango hueco, 8 mm
poignée creuse, 8 mm
manico cavo, 8 mm

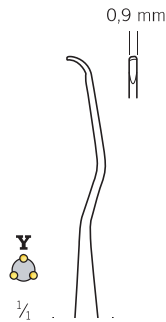

43-336-02-07

Fig. 1/2

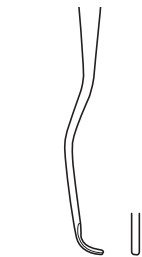

Frontzähne, universell,
längerer 1er Schaft,
kürzeres Arbeitsende

Incisors, universal,
first shaft longer, working
end shorter

Incisivos, universal,
vástago 1, más largo,
punta de trabajo más corta

Incisives, universal,
1ère tige plus longue,
extrémité opératoire plus
courte

Incisivi, universali,
1° stelo più lungo,
estremità di lavoro più breve

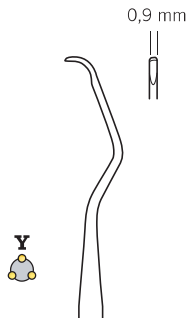

43-336-04-07

Fig. 3/4



Frontzähne, Prämolaren,
universell,
längerer 1er Schaft,
kürzeres Arbeitsende

Incisors, premolars,
universal,
first shaft longer,
working end shorter

Incisivos, premolares,
universal,
vástago 1, más largo,
punta de trabajo más corta

Incisives, universal,
1ère tige plus longue,
extrémité opératoire plus
courte

Incisivi, premolari,
universali,
1° stelo più lungo,
estremità di lavoro più breve

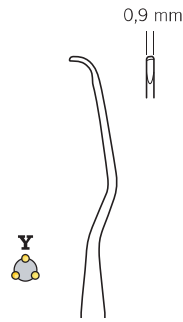

43-336-06-07

Fig. 5/6



Frontzähne, Prämolaren,
universell,
längerer 1er Schaft, kürzeres
Arbeitsende

Incisors, premolars,
universal,
first shaft longer,
working end shorter

Incisivos, premolares,
universal,
vástago 1, más largo,
punta de trabajo más corta

Incisives, universal,
1ère tige plus longue,
extrémité opératoire plus
courte

Incisivi, premolari,
universali,
1° stelo più lungo,
estremità di lavoro più breve

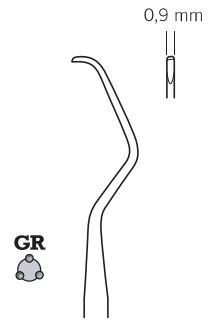

43-336-08-07

Fig. 7/8

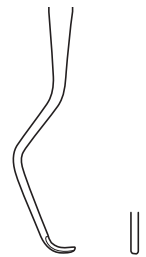

Prämolaren, Molaren,
lingual/bukkal,
längerer 1er Schaft,
kürzeres Arbeitsende

Premolars, molars,
lingual/buccal,
first shaft longer, working
end shorter

Premolares, molares,
lingual/bucal, vástago 1,
más largo, punta de trabajo
más corta

Prémolaires, molaires,
lingual/bucal,
1ère tige plus longue,
extrémité opératoire plus
courte

Premolari, molari,
linguali/buccali,
1° stelo più lungo,
estremità di lavoro più breve

GR = grau
grey
gris
gris
grigio

Y = gelb
yellow
amarillo
jaune
giallo

R = rot
red
rojo
rouge
rosso

G = grün
green
verde
vert
verde

V = violett
violet
violeta
violet
viola

W = weiß
white
blanco
blanc
bianco

B = blau
blue
azur
bleu
blu

N = schwarz
black
negro
noir
nero

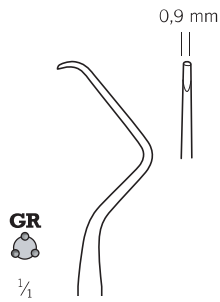
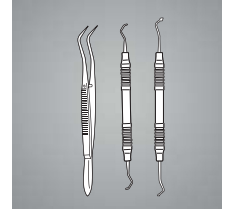

43-336-10-07
 Fig. 9/10

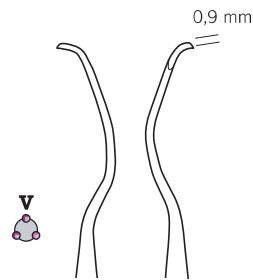

43-336-12-07
 Fig. 11/12

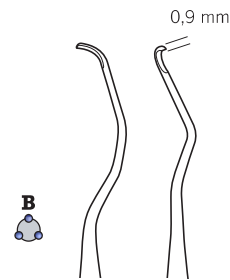

43-336-14-07
 Fig. 13/14

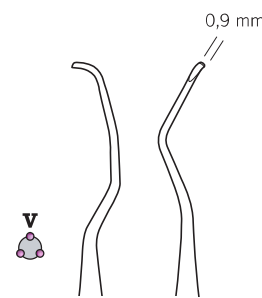

43-336-16-07
 Fig. 15/16

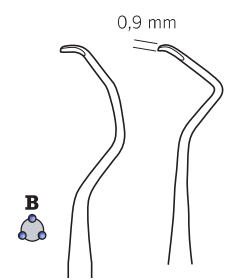

43-336-18-07
 Fig. 17/18

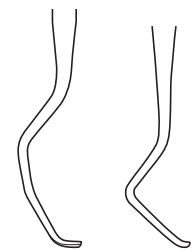
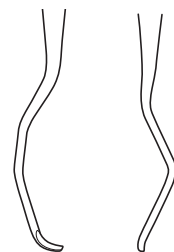
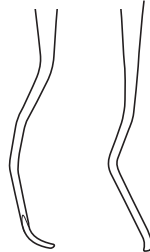
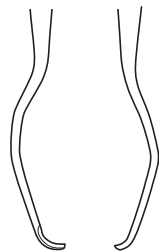
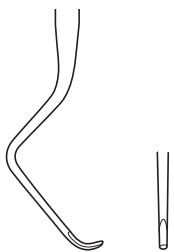

Prämolaren, Molaren, lingual/bukkal, längerer 1er Schaft, kürzeres Arbeitsende
 Premolars, molars, lingual/buccal, first shaft longer, working end shorter
 Premolares, molares, lingual/buccal, vástago 1, más largo, punta de trabajo más corta
 Prémolaires, molaires, lingual/buccal, 1ère tige plus longue, extrémité opératoire plus courte
 Premolari, molari, linguali/buccali, 1° stelo più lungo, estremità di lavoro più breve

Prämolaren, Molaren, mesial, mesiolingual, mesiobukkal, längerer 1er Schaft, kürzeres Arbeitsende
 Premolars, molars, mesial, mesiolingual, mesiobuccal, first shaft longer, working end shorter
 Premolares, molares, mesial, mesiolingual, mesiobuccal, vástago 1, más largo, punta de trabajo más corta
 Prémolaires, molaires, mesial, mesiolingual, mesiobuccal, 1ère tige plus longue, extrémité opératoire plus courte
 Premolari, molari, mesiali, mesiolinguali, mesiobuccali, 1° stelo più lungo, estremità di lavoro più breve

Prämolaren, Molaren, distal, längerer 1er Schaft, kürzeres Arbeitsende
 Premolars, molars, distal, first shaft longer, working end shorter
 Premolares, molares, distal, vástago 1, más largo, punta de trabajo más corta
 Prémolaires, molaires, distal, 1ère tige plus longue, extrémité opératoire plus courte
 Premolari, molari, distali, 1° stelo più lungo, estremità di lavoro più breve

Prämolaren, Molaren, mesial, längerer 1er Schaft, kürzeres Arbeitsende
 Premolars, molars, mesial, first shaft longer, working end shorter
 Premolares, molares, mesial, vástago 1, más largo, punta de trabajo más corta
 Prémolaires, molaires, mesial, 1ère tige plus longue, extrémité opératoire plus courte
 Premolari, molari, mesiali, distali, 1° stelo più lungo, estremità di lavoro più breve

Prämolaren, Molaren, distal, längerer 1er Schaft, kürzeres Arbeitsende
 Premolars, molars, distal, first shaft longer, working end shorter
 Premolares, molares, distal, vástago 1, más largo, punta de trabajo más corta
 Prémolaires, molaires, distal, 1ère tige plus longue, extrémité opératoire plus courte
 Premolari, molari, distali, 1° stelo più lungo, estremità di lavoro più breve

Gracey Standard-Küretten, subgingivaler Einsatz

Gracey standard curettes, subgingival

Gracey curetas estándar, subgingival

Gracey curettes standard, subgingival

Gracey curette standard, subgingivale

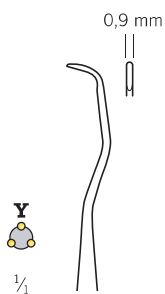

43-337-02-07

Fig. 1/2



Frontzähne, universell
Incisors, universal
Incisivos, universal
Incisives, universal
Incisivi, universali

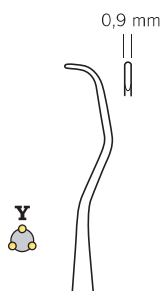

43-337-04-07

Fig. 3/4



Frontzähne, Prämolaren,
universell
Incisors, premolars,
universal
Incisivos, premolares,
universal
Incisives, prémolaires,
universel
Incisivi, premolari,
universali

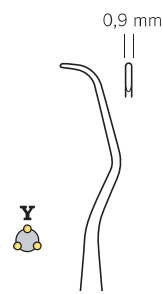

43-337-06-07

Fig. 5/6



Frontzähne, Prämolaren,
universell
Incisors, premolars,
universal
Incisivos, premolares,
universal
Incisives, prémolaires,
universel
Incisivi, premolari,
universali

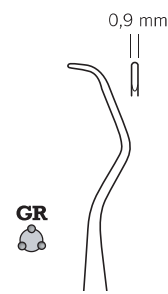

43-337-08-07

Fig. 7/8



Prämolaren, Molaren,
lingual / bukkal
Premolars, molars,
lingual / buccal
Prémolaires, molares,
lingual / bucal
Prémolaires, molaires,
lingual / buccal
Premolari, molari,
linguali / buccali

Gracey Standard
43-337-02-07 -
43-337-18-07

17,5 cm / 6 7/8"

Hohlgriff, 8 mm
hollow handle, 8 mm
mango hueco, 8 mm
poignée creuse, 8 mm
manico cavo, 8 mm

GR = grau
grey
gris
gris
grigio

Y = gelb
yellow
amarillo
jaune
giallo

R = rot
red
rojo
rouge
rosso

G = grün
green
verde
vert
verde

V = violett
violet
violeta
violet
viola

W = weiß
white
blanco
blanc
bianco

B = blau
blue
azur
bleu
blu

N = schwarz
black
negro
noir
nero

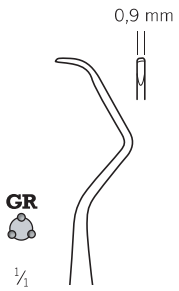
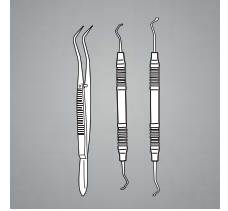

43-337-10-07
 Fig. 9/10

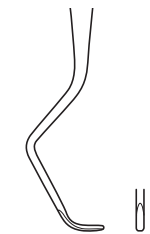

Prämolaren, Molaren,
 lingual / bukkal
 Premolars, molars,
 lingual / buccal
 Premolares, molares,
 lingual / bucal
 Prémolaires, molaires,
 lingual / buccal
 Premolari, molari,
 linguali / buccali

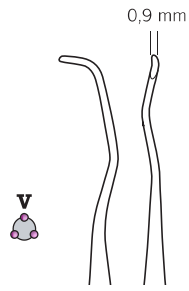

43-337-12-07
 Fig. 11/12



Prämolaren, Molaren,
 mesial, mesiolingual,
 mesiobukkal
 Premolars, molars, mesial,
 mesiolingual, mesiobuccal
 Premolares, molares, mesial,
 mesiolingual, mesiobuccal
 Prémolaires, molaires,
 mesial, mesiolingual,
 mesiobuccal
 Premolari, molari, mesiali,
 mesiolinguali, mesiobuccali

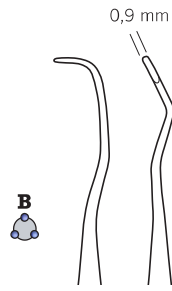

43-337-14-07
 Fig. 13/14

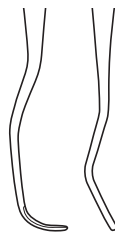

Prämolaren, Molaren, distal
 Premolars, molars, distal
 Premolares, molares, distal
 Prémolaires, molaires, distal
 Premolari, molari, distali

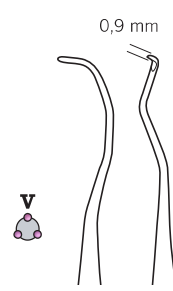

43-337-16-07
 Fig. 15/16



Prämolaren, Molaren, mesial
 Premolars, molars, mesial
 Premolares, molares, mesial
 Prémolaires, molaires, mésial
 Premolari, molari, mesiali

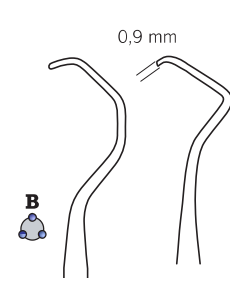

43-337-18-07
 Fig. 17/18

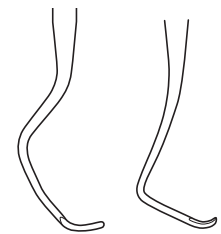

Prämolaren, Molaren, distal
 Premolars, molars, distal
 Premolares, molares, distal
 Prémolaires, molaires, distal
 Premolari, molari, distali

Gracey Rigid-Küretten, subgingivaler Einsatz

Gracey Rigid curettes, subgingival

Gracey Rigid curetas, subgingival

Gracey Rigid curettes, subgingival

Gracey Rigid curette, subgingivale

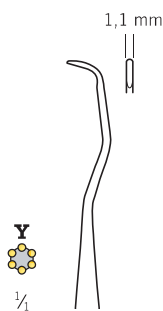

43-338-02-07

Fig. 1/2



Frontzähne, universell,
extra starr, für hartnäckige
Zahnbeläge

Incisors, universal,
extra rigid, for stubborn
dental plaque

Incisivos, universal,
extrarígido, para sarro
persistente

Incisives, universel,
extra rigide, pour tartes
tenaces

Incisivi, universali,
extrarígido, per placca
dentaria persistente

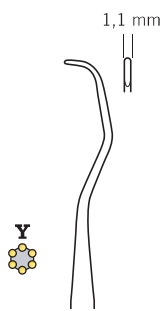

43-338-04-07

Fig. 3/4



Frontzähne, Prämolaren,
universell,
extra starr, für hartnäckige
Zahnbeläge

Incisors, premolars,
universal,
extra rigid, for stubborn
dental plaque

Incisivos, premolares,
universal,
extrarígido, para sarro
persistente

Incisives, prémolaires,
universel
extra rigide, pour tartes
tenaces

Incisivi, premolari, universali,
extrarígido, per placca
dentaria persistente

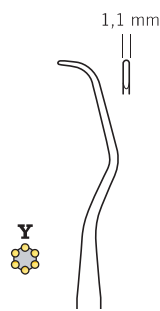

43-338-06-07

Fig. 5/6



Frontzähne, Prämolaren,
universell,
extra starr, für hartnäckige
Zahnbeläge

Incisors, premolars,
universal,
extra rigid, for stubborn
dental plaque

Incisivos, premolares,
universal,
extrarígido, para sarro
persistente

Incisives, prémolaires,
universel,
extra rigide, pour tartes
tenaces

Incisivi, premolari, universali,
extrarígido, per placca
dentaria persistente

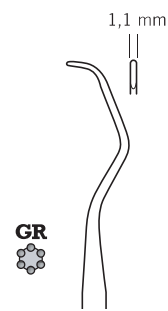

43-338-08-07

Fig. 7/8



Prämolaren, Molaren,
lingual, bukkal,
extra starr, für hartnäckige
Zahnbeläge

Premolars, molars, lingual,
buccal,
extra rigid, for stubborn
dental plaque

Premolares, molares, lingual,
buccal,
extrarígido, para sarro
persistente

Prémolaires, molaires,
lingual, buccal,
extra rigide, pour tartes
tenaces

Premolari, molari, linguali,
buccali,
extrarígido, per placca
dentaria persistente

Gracey Rigid
43-338-02-07 -
43-338-18-07

17,5 cm / 6 7/8"

Hohlgriff, 8 mm
hollow handle, 8 mm
mango hueco, 8 mm
poignée creuse, 8 mm
manico cavo, 8 mm

GR = grau
grey
gris
gris
grigio

Y = gelb
yellow
amarillo
jaune
giallo

R = rot
red
rojo
rouge
rosso

G = grün
green
verde
vert
verde

V = violett
violet
violeta
violet
viola

W = weiß
white
blanco
blanc
bianco

B = blau
blue
azur
bleu
blu

N = schwarz
black
negro
noir
nero

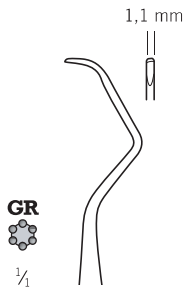
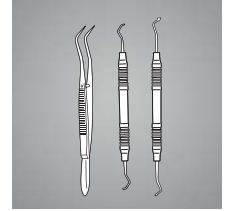

43-338-10-07
Fig. 9/10

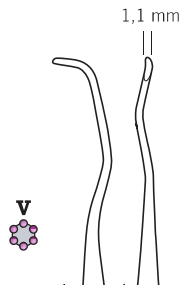

43-338-12-07
Fig. 11/12

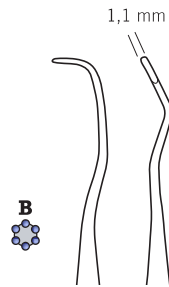

43-338-14-07
Fig. 13/14

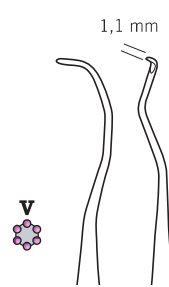

43-338-16-07
Fig. 15/16

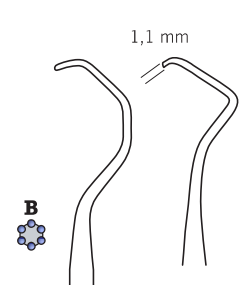

43-338-18-07
Fig. 17/18

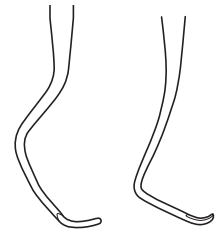
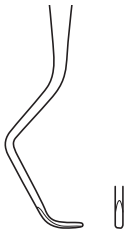

Prämolaren, Molaren, lingual, bukkal, extra starr, für hartnäckige Zahnbeläge

Premolars, molars, lingual, buccal, extra rigid, for stubborn dental plaque

Premolares, molares, lingual, buccal, extrarígido, para sarro persistente

Prémolaires, molaires, lingual, buccal, extra rigide, pour tartes tenaces

Premolari, molari, linguali, buccali, extrarígido, per placca dentaria persistente

Prämolaren, Molaren, mesial, mesiolingual, mesiobukkal extra starr, für hartnäckige Zahnbeläge

Premolars, molars, mesial, mesiolingual, mesiobuccal, extra rigid, for stubborn dental plaque

Premolares, molares, mesial, mesiolingual, mesiobuccal, extrarígido, para sarro persistente

Prémolaires, molaires, mésial, mésiolingual, mésiobuccal, extra rigide, pour tartes tenaces

Premolari, molari, mesiali, mesiolinguali, mesiobuccali, extrarígido, per placca dentaria persistente

Prämolaren, Molaren, distal extra starr, für hartnäckige Zahnbeläge

Premolars, molars, distal extra rigid, for stubborn dental plaque

Premolares, molares, distal, extrarígido, para sarro persistente

Prémolaires, molaires, distal, extra rigide, pour tartes tenaces

Premolari, molari, distali, extrarígido, per placca dentaria persistente

Prämolaren, Molaren, mesial, extra starr, für hartnäckige Zahnbeläge

Premolars, molars, mesial, distal extra rigid, for stubborn dental plaque

Premolares, molares, mesial, extrarígido, para sarro persistente

Prémolaires, molaires, mésial, extra rigide, pour tartes tenaces

Premolari, molari, mesiali, distali, extrarígido, per placca dentaria persistente

Prämolaren, Molaren, distal extra starr, für hartnäckige Zahnbeläge

Premolars, molars, distal extra rigid, for stubborn dental plaque

Premolares, molares, distal, extrarígido, para sarro persistente

Prémolaires, molaires, distal, extra rigide, pour tartes tenaces

Premolari, molari, distali, extrarígido, per placca dentaria persistente

Gracey Küretten mit 10 mm-Griff

Gracey curettes with 10 mm handle
 Gracey curetas para mangos 10 mm
 Gracey curettes avec manches à 10 mm
 Gracey curette con manici 10 mm

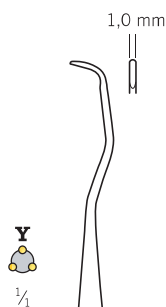

43-339-02-07

Fig. 1/2



Frontzähne, universell
 Incisors, universal
 Incisivos, universal
 Incisives, universel
 Incisivi, universali

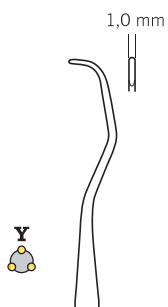

43-339-04-07

Fig. 3/4



Frontzähne, Prämolaren,
 universell
 Incisors, premolars, universal
 Incisivos, premolares,
 universal
 Incisives, prémolaires,
 universel
 Incisivi, premolari, universali

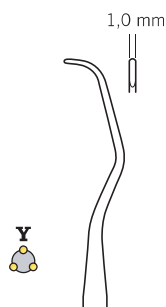

43-339-06-07

Fig. 5/6



Frontzähne, Prämolaren,
 universell
 Incisors, premolars, universal
 Incisivos, premolares,
 universal
 Incisives, prémolaires,
 universel
 Incisivi, premolari, universali

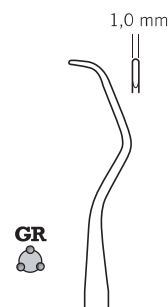

43-339-08-07

Fig. 7/8



Prämolaren, Molaren,
 lingual, bukkal
 Premolars, molars, lingual,
 buccal
 Premolares, molares, lingual,
 bucal
 Prémolaires, molaires,
 lingual, buccal
 Premolari, molari, linguali,
 buccali

Big Gracey
 43-339-02-07 -
 43-339-18-07

17,5 cm / 6 7/8"

Hohlgriff, 10 mm
 hollow handle, 10 mm
 mango hueco, 10 mm
 poignée creuse, 10 mm
 manico cavo, 10 mm

GR = grau
 grey
 gris
 gris
 grigio

Y = gelb
 yellow
 amarillo
 jaune
 giallo

R = rot
 red
 rojo
 rouge
 rosso

G = grün
 green
 verde
 vert
 verde

V = violett
 violet
 violeta
 violet
 viola

W = weiß
 white
 blanco
 blanc
 bianco

B = blau
 blue
 azur
 bleu
 blu

N = schwarz
 black
 negro
 noir
 nero

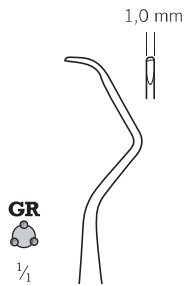
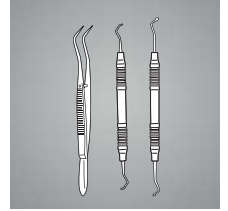

43-339-10-07
 Fig. 9/10

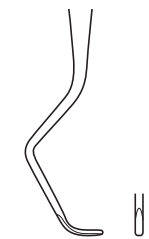

Prämolaren, Molaren, lingual, bukkal
 Premolars, molars, lingual, buccal
 Premolares, molares, lingual, bucal
 Prémolaires, molaires, lingual, buccal
 Premolari, molari, linguale, buccali

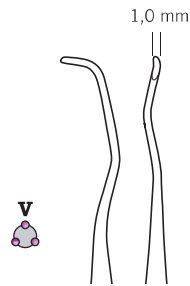

43-339-12-07
 Fig. 11/12



Prämolaren, Molaren, mesial, mesiolingual, mesiobukkal
 Premolars, molars, mesial, mesiolingual, mesiobuccal
 Premolares, molares, mesial, mesiolingual, mesiobuccal
 Prémolaires, molaires, mésial, mésiolingual, mésiobuccal
 Premolari, molari, mesiali, mesiolinguali, mesiobuccali

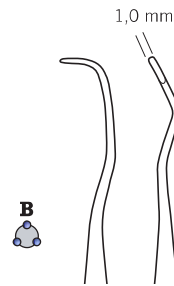

43-339-14-07
 Fig. 13/14



Prämolaren, Molaren, distal
 Premolars, molars, distal
 Premolares, molares, distal
 Prémolaires, molaires, distal
 Premolari, molari, distali

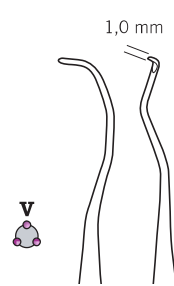

43-339-16-07
 Fig. 15/16



Prämolaren, Molaren, mesial
 Premolars, molars, mesial
 Premolares, molares, mesial
 Prémolaires, molaires, mésial
 Premolari, molari, mesiali

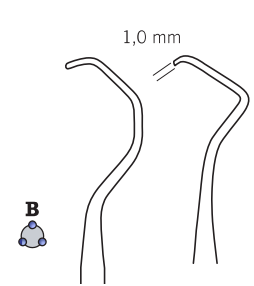

43-339-18-07
 Fig. 17/18

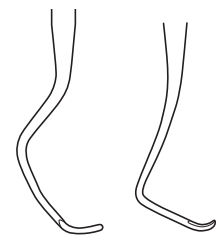

Prämolaren, Molaren, distal
 Premolars, molars, distal
 Premolares, molares, distal
 Prémolaires, molaires, distal
 Premolarim molari, distali

Küretten, subgingivaler Einsatz

Curettes, subgingival

Curetas, subgingival

Curettes, subgingival

Curette, subgingivale



43-350-01-07

Fig. 1



Furkationskürette
Furcation curette
Cureta de furcación
Curette à furcation
Curetta di forcazione
0,9 mm
bukkal / lingual
buccal / lingual
bucal / lingual
buccal / lingual
buccali / linguali



43-350-02-07

Fig. 2



Furkationskürette
Furcation curette
Cureta de furcación
Curette à furcation
Curetta di forcazione
3 mm
bukkal / lingual
buccal / lingual
bucal / lingual
buccal / lingual
buccali / linguali



43-350-03-07

Fig. 3



Furkationskürette
Furcation curette
Cureta de furcación
Curette à furcation
Curetta di forcazione
0,9 mm
mesial / distal
mesial / distal
mesial / distal
mésial / distal
mesiali / distali



43-350-04-07

Fig. 4



Furkationskürette
Furcation curette
Cureta de furcación
Curette à furcation
Curetta di forcazione
1,3 mm
mesial / distal
mesial / distal
mesial / distal
mésial / distal
mesiali / distali

43-350-01-07 -
43-350-04-07

17,5 cm / 6 7/8"

Hohlgriff, 8 mm
hollow handle, 8 mm
mango hueco, 8 mm
poignée creuse, 8 mm
manico cavo, 8 mm

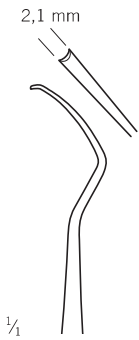
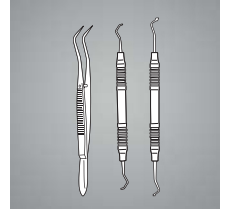

43-350-05-07
 Fig. 5



Furkationskürette
 Furcation curette
 Cureta de furcación
 Curette à furcation
 Curetta di forcazione
 0,9 mm
 labial / lingual
 labial / lingual
 labiale / lingual
 labiali / linguali

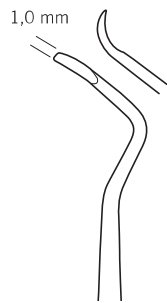

Prichard
 43-364-01-07
 Fig. 1/2



Chirurgische Kürette,
 extra lange, kräftige
 Konstruktion,
 zweiseitig

Bone curette,
 extra long, robust
 construction, double
 cutting

Cureta para hueso,
 construcción robusta
 extralarga, doble
 cortante

Curette à os,
 construction très
 longue, robuste,
 double coupe

Curetta ossea,
 design extralungo,
 robusto, doppio
 taglio



Gracey Mini-Küretten, subgingivaler Einsatz

Gracey mini curettes, subgingival

Gracey mini curetas, subgingival

Gracey mini curettes, subgingival

Gracey mini curette, subgingivale



Frontzähne, Prämolaren,
universell,
längerer 1er Schaft,
kürzeres Arbeitsende

Incisors, premolars,
universal,
first shaft longer,
working end shorter

Incisivos, premolares,
universal,
vástago 1, más largo,
punta de trabajo más corta

Incisives, universal,
1ère tige plus longue,
extrémité opératoire plus
courte

Incisivi, premolari,
universali,
1° stelo più lungo,
estremità di lavoro più breve

1/4

43-334-06-07

Ti

Fig. 5/6

17,5 cm / 6 7/8"

Hohlgriff, 10 mm
hollow handle, 10 mm
mango hueco, 10 mm
poignée creuse, 10 mm
manico cavo, 10 mm

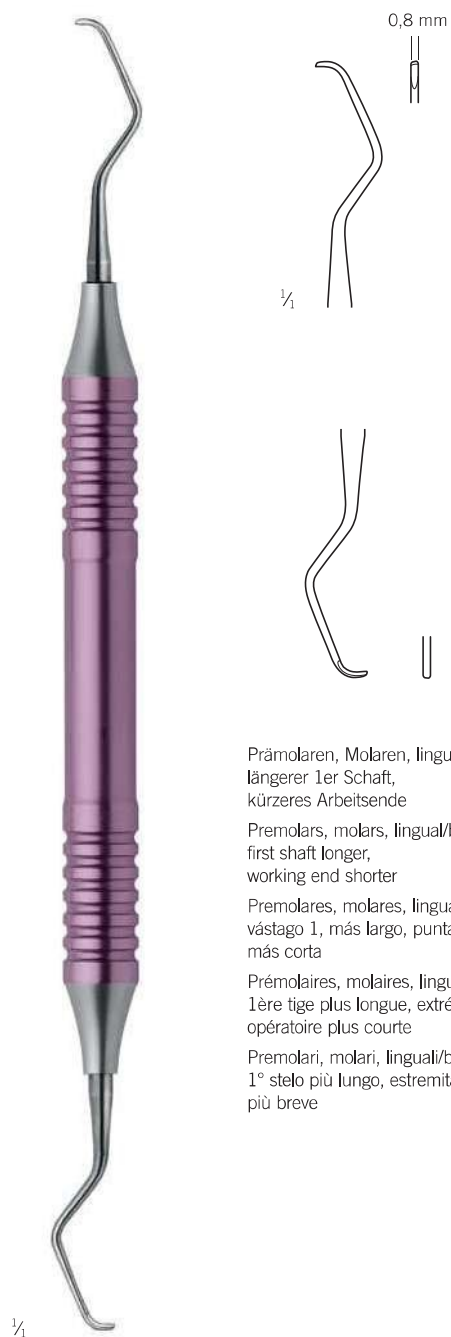

Prämolaren, Molaren, lingual/bukkal,
längerer 1er Schaft,
kürzeres Arbeitsende

Premolars, molars, lingual/buccal,
first shaft longer,
working end shorter

Premolares, molares, lingual/bucal,
vástago 1, más largo, punta de trabajo
más corta

Prémolaires, molaires, lingual/bucal,
1ère tige plus longue, extrémité
opératoire plus courte

Premolari, molari, linguale/buccali,
1° stelo più lungo, estremità di lavoro
più breve

1/4

43-334-08-07

Ti

Fig. 7/8

17,5 cm / 6 7/8"

Hohlgriff, 10 mm
hollow handle, 10 mm
mango hueco, 10 mm
poignée creuse, 10 mm
manico cavo, 10 mm

Reinigungsinstrumente

Scalers, periodontology
Limpiadores de sarro, parodontología
Instruments à détartrer, parodontologie
Ablatori di tartaro, parodontologia

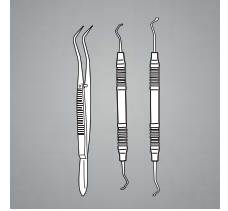

43

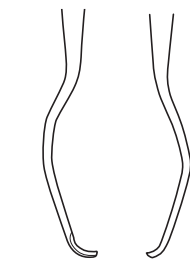
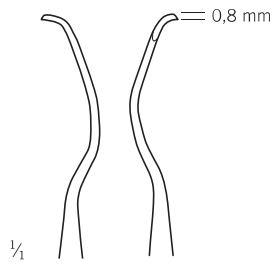

Prämolaren, Molaren,
mesial, mesiolingual,
mesiobukkal,
längerer 1er Schaft,
kürzeres Arbeitsende
Premolars, molars,
mesial, mesiolingual,
mesiobuccal,
first shaft longer, working
end shorter
Prémolares, molares,
mesial, mesiolingual,
mesiobucal, vástago 1,
más largo,
punta de trabajo más corta

Prémolaires, molaires,
mésial, mésiolingual,
mésiobuccal,
1ère tige plus longue,
extrémité opératoire plus
courte
Premolari, molari,
mesiali, mesiolinguali,
mesiobuccali,
1° stelo più lungo, estremità
di lavoro più breve

1/4

43-334-12-07



Fig. 11/12

17,5 cm / 6 7/8"

Hohlgriff, 10 mm
hollow handle, 10 mm
mango hueco, 10 mm
poignée creuse, 10 mm
manico cavo, 10 mm

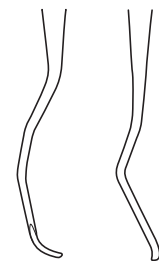
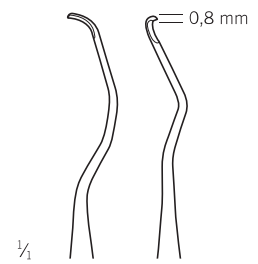

Prämolaren, Molaren, distal,
längerer 1er Schaft, kürzeres
Arbeitsende

Premolars, molars, distal,
first shaft longer, working
end shorter

Prémolares, molares, distal,
vástago 1, más largo, punta
de trabajo más corta

Prémolaires, molaires, distal,
1ère tige plus longue,
extrémité opératoire plus
courte

Premolari, molari, distali,
1° stelo più lungo, estremità
di lavoro più breve

1/4

43-334-14-07



Fig. 13/14

17,5 cm / 6 7/8"

Hohlgriff, 10 mm
hollow handle, 10 mm
mango hueco, 10 mm
poignée creuse, 10 mm
manico cavo, 10 mm

Gracey Standard-Küretten, subgingivaler Einsatz

Gracey standard curettes, subgingival

Gracey curetas estándar, subgingival

Gracey curettes standard, subgingival

Gracey curette standard, subgingivale

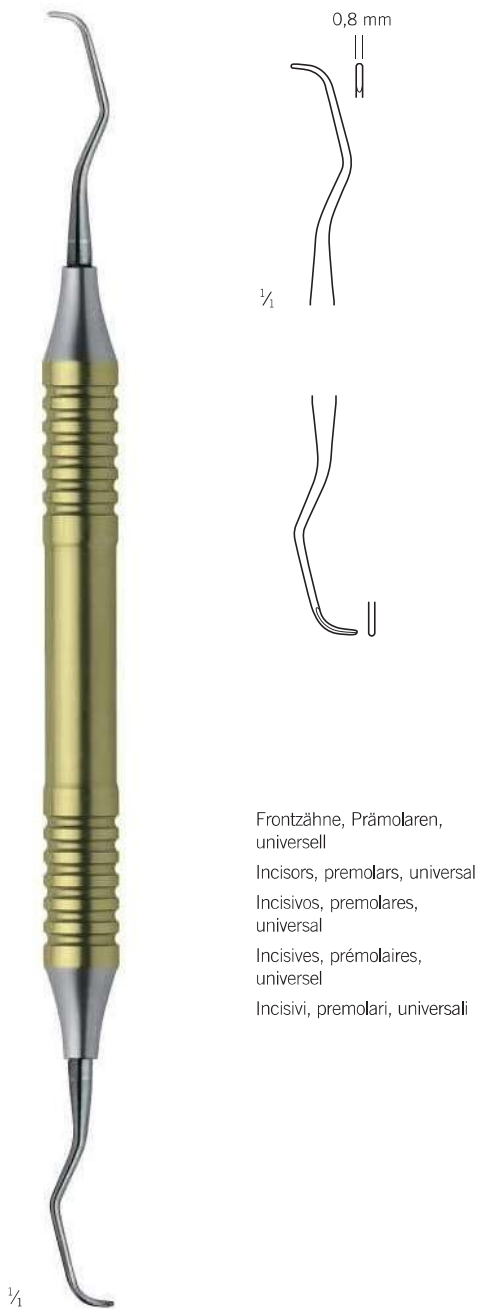

Frontzähne, Prämolaren,
universell
Incisors, premolars, universal
Incisivos, premolares,
universal
Incisives, prémolaires,
universel
Incisivi, premolari, universali

43-335-06-07 Ti

Fig. 5/6

17,5 cm / 6 7/8"

Hohlgriff, 10 mm
hollow handle, 10 mm
mango hueco, 10 mm
poignée creuse, 10 mm
manico cavo, 10 mm

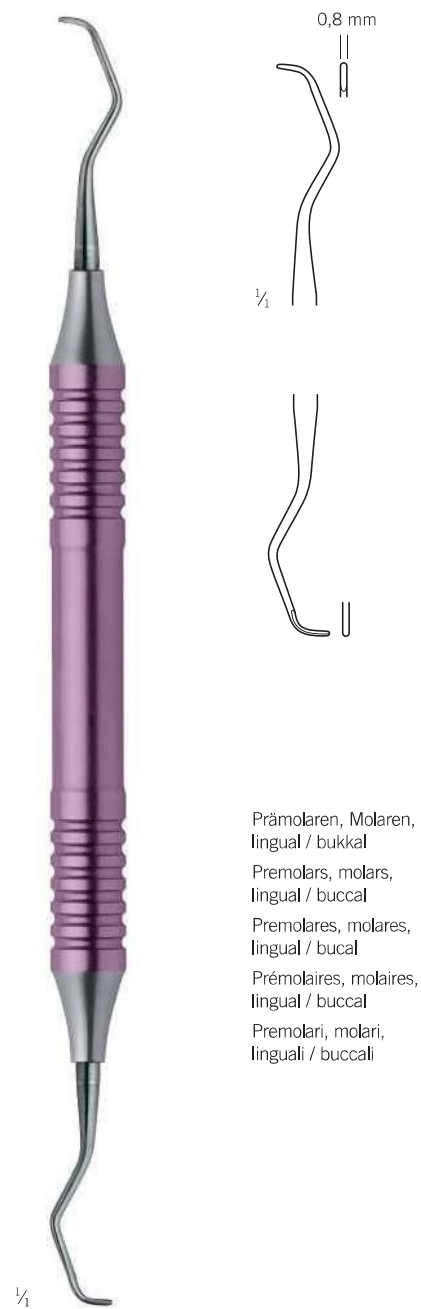

Prämolaren, Molaren,
lingual / bukkal
Premolars, molars,
lingual / buccal
Prémolaires, molaires,
lingual / bucal
Prémolaires, molaires,
lingual / buccal
Premolari, molari,
linguali / buccali

43-335-08-07 Ti

Fig. 7/8

17,5 cm / 6 7/8"

Hohlgriff, 10 mm
hollow handle, 10 mm
mango hueco, 10 mm
poignée creuse, 10 mm
manico cavo, 10 mm

Reinigungsinstrumente

Scalers, periodontology
 Limpiadores de sarro, parodontología
 Instruments à détartrer, parodontologie
 Ablatori di tartaro, parodontologia

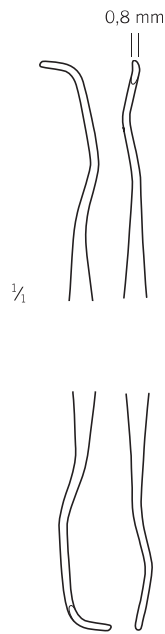
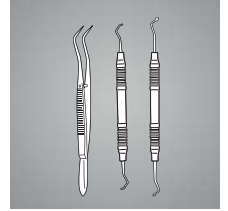

Prämolaren, Molaren, mesial,
 mesiolingual, mesiobukkal
 Premolars, molars, mesial,
 mesiolingual, mesiobuccal
 Premolares, molares, mesial,
 mesiolingual, mesiobuccal
 Prémolaires, molaires, mésial,
 mésiolingual, mésiobuccal
 Premolari, molari, mesiali,
 mesiolinguali, mesiobuccali

1/4

43-335-12-07



Fig. 11/12

17,5 cm / 6 7/8"

Hohlgriff, 10 mm
 hollow handle, 10 mm
 mango hueco, 10 mm
 poignée creuse, 10 mm
 manico cavo, 10 mm

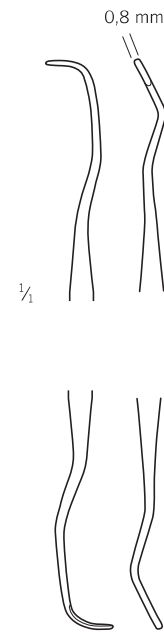

Prämolaren, Molaren, distal
 Premolars, molars, distal
 Premolares, molares, distal
 Prémolaires, molaires, distal
 Premolari, molari, distali

1/4

43-335-14-07



Fig. 13/14

17,5 cm / 6 7/8"

Hohlgriff, 10 mm
 hollow handle, 10 mm
 mango hueco, 10 mm
 poignée creuse, 10 mm
 manico cavo, 10 mm

Schleifsteine

Sharpening stones

Piedras de afilar

Meules

Pietre per affilare



Record Arkansas 43-840-00-04

115 x 40 x 10/2 mm

Multiform, weiß
multi shape, white
forma múltiple, blanco
multiforme, blanc
multiforme, bianco

Zum Vorschleifen stumpfer Instrumente.
Mit abgerundeten Kanten und abgeschrägten
Flächen für Radien und Flächen

For pregrinding of blunt instruments. The
rounded edges and bevelled surfaces enable
the sharpening of radius and surfaces

Para preafilar instrumentos romos. Los cantos
redondeados y las superficies biseladas
permiten afilar radios y superficies

Pour le dégrossissage d'instruments émoussés.
Avec bords arrondies et surfaces en biseau
pour rayons et surfaces

Per la sgrassatura degli strumenti smussati.
Con bordi arrotondati e superfici smussate
consentono di affilare radi e superfici



Original Arkansas 43-840-01-04

100 x 25 x 7 mm

flach, grau-weiß
flat, grey-white
plano, blanco-gris
plat, blanc-gris
piatto, bianco-grigio

Zum wiederholten Aufschleifen sowie Finieren von Scalern
und Küretten

For repeated grinding and finishing of scalers and
curettes

Para el afilado continuo y acabado de limpiadores y
curetas

Pour le polissage répété ainsi que la finition
d'instruments pour enlever la tartre et curettes

Per una ripetuta molatura e finitura di ablatori di tartaro e
curette



Original Arkansas 43-840-02-04

100 mm lang, Ø 8 mm

rund, grau-weiß
round, grey-white
redondo, blanco-gris
rond, blanc-gris
rotondo, bianco-grigio

Zum Entgraten der Federkanten
For burr removing from cutting edges
Para quitar la rebaba de los filos
Pour l'ébarbage des bords
Per la sbavatura dei bordi



India-Korund 43-840-05-04

115 x 45 x 2 - 10 mm

fein, braun-beige
delicate, brown-beige
delicado, marrón-beige
fin, brun-beige
fine, beige-marrone

Zum Vorschleifen von sehr stumpfen Instrumenten
For sharpening and recontouring of very blunt
instruments

Para preafilar y volverles a dar forma a instrumentos
Pour le dégrossissage d'instruments émoussés
Per la sgrassatura di strumenti molto smussati



India-Korund 43-840-06-04

100 mm lang, Ø 5 - 10 mm

rund, fein, braun-beige
round, delicate, brown-beige
redondo, delicado, marrón-beige
rond, fin, brun-beige
rotondo, file, beige-marrone

Zum Entgraten von Federkanten
For burr removing from cutting edges
Para quitar la rebaba de los filos
Pour l'ébarbage des bords
Per la sbavatura dei bordi



43-840-08-04

75 mm lang, Ø 6,0 mm

Teststäbchen aus Kunststoff
Test stick plastic
Varita de prueba de plástico
Bâtonnets pour test en plastique
Asta per test in plastica

Verpackungseinheit 6 Stück
package of 6 pieces
embalaje de 6 piezas
unité de commande 6 pièces
confezione da 6 pezzi

Zur Kontrolle der Schneidwirkung von Scalern und
Küretten
For testing the sharpness of scalers and curettes
Para probar el filo de limpiadores y curetas
Pour le contrôle de l'effet de coupe d'instruments
pour enlever le tartre et de curettes
Per il controllo dell'effetto di taglio di ablatori di
tartaro e curette

Reinigungsinstrumente

Scalers, periodontology
Limpiadores de sarro, parodontología
Instruments à détartrer, parodontologie
Ablatori di tartaro, parodontologia

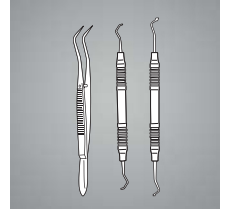

43



Record Arkansas
10-875-00-04

150 x 50 mm
im Holzkasten
in wooden case
en estuche de madera
en conteneur en bois
in contenitori di legno



43-840-09-04

Schleifsteinöl
Sharpening stone oil
Aceite para piedras de afilar
Huile à pierre à aiguiser
Olio per pietra abrasiva

Parodontometer

Periodontal probes

Sondas parodontales

Sondes parodontales

Sonde parodontali



43-300-01-07

Iglhaut
43-300-01-07

17,5 cm / 6 7/8"

massiver Griff, 6 mm,
solid handle, 6 mm
mango sólido, 6 mm
poignée massive, 6 mm
solida impugnatura, 6 mm



43-347-40-07

Nabers
43-347-40-07

17,5 cm / 6 7/8"

Hohlgriff, 8 mm
hollow handle, 8 mm
mango hueco, 8 mm
poignée creuse, 8 mm
manico cavo, 8 mm

Furkationssonde, graduiertes Arbeitsende
Furcation probe, graduated working end
Sonda de furcación, punta de trabajo graduada
Sonde de furcation, extrémité opératoire graduée
Sonda di forcazione, estremità di lavoro graduata



43-356-08-07

Fig. 8

Grad. 3-6-8-11

43-356-10-07

Fig. 10

Grad. 1-2-3-5-7-8-9-10

43-356-11-07

Fig. 11

Grad. 3-6-8-11

43-357-00-07

Fig. W

Grad. 1-2-3-5-7-8-9-10

43-356-08-07 - 43-357-00-07

16 cm / 6 1/8"

massiver Griff, 6 mm,
solid handle, 6 mm
mango sólido, 6 mm
poignée massive, 6 mm
solida impugnatura, 6 mm

Parodontometer-Ansatz

Periodontal probes, interchangeable
 Sondas parodontales, intercambiables
 Sondes parodontales, interchangeables
 Sonde parodontali, intercambiabili

Reinigungsinstrumente

Scalers, periodontology
 Limpiadores de sarro, parodontología
 Instruments à détartrer, parodontologie
 Ablatori di tartaro, parodontologia

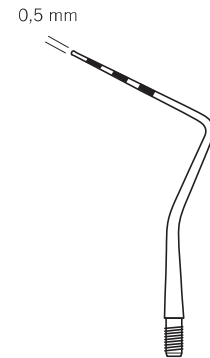
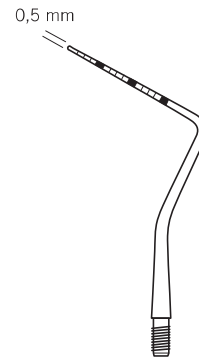
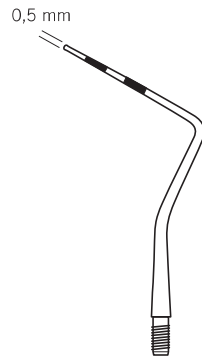
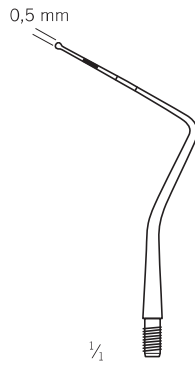
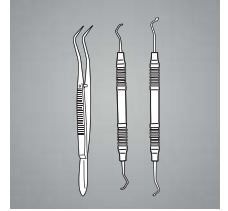

43-734-11-07

43-735-11-09

Fig. CPG 11,5 WHO

Grad. 3,5-5,5-8,5-11,5

mit Kugel
 with ball
 con bola
 avec bille
 con sfera

43-734-13-07

43-735-13-09

Fig. CPG 12

Grad. 3-6-9-12

43-734-21-07

43-735-21-09

Fig. CP 15 UNC

Grad. 1-2-3-4-...-14-15

43-734-23-07

43-735-23-09

Fig. CPNG 22

Grad. 2-4-6-8-10-12



Sondengriffe siehe Seite 244
 Probe handles see page 244
 Mangos endosondas miren página 244
 Poignées endosondes voir page 244
 Impugnatori endosonde vedi pagina 244

Parodontometer

Periodontal probes
 Sondas parodontales
 Sondes parodontales
 Sonde parodontali

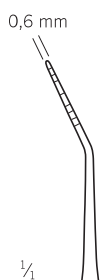

Merrit A
 43-736-00-07
 Grad. 1-2-3-5-7-8-9-10

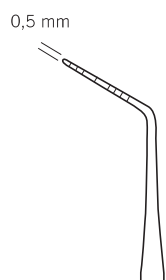

Merrit E
 43-736-01-07
 Grad. 1-2-3-5-7-8-9-10

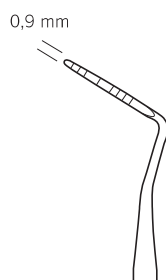

Goldman-Fox
 43-736-04-07
 Grad. 1-2-3-5-7-8-9-10



Michigan
 43-736-06-07
 Grad. 3-6-8

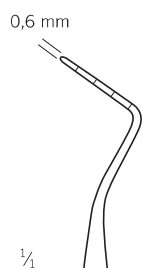

Mercury
 43-736-08-07
 Grad. 3-6-9-12

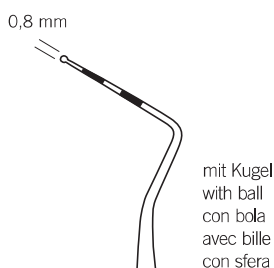

43-736-10-07
 Fig. CPNG 12S
 Grad. 3-6-9-12

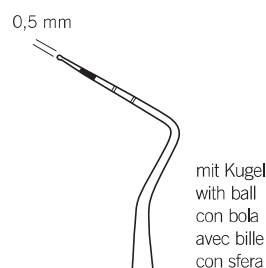

WHO
 43-736-11-07
 Fig. CPG 11,5 WHO
 Grad. 3,5-5,5-8,5-11,5

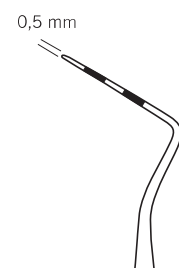

43-736-12-07
 Fig. CPG 12
 Grad. 3-6-9-12

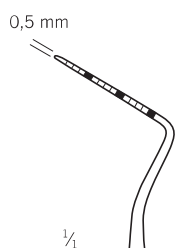

43-736-15-07
 Fig. CP 15 UNC
 Grad. 1-2-3-4-5 ... 14-15

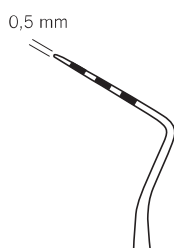

43-736-22-07
 Fig. CPNG 22
 Grad. 2-4-6-8-10-12

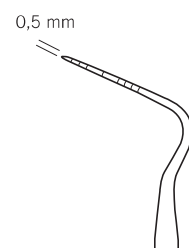

43-736-26-07
 Fig. 26G
 Grad. 1-2-3-5-7-8-9-10

43-736-00-07 -
 43-736-26-07
 17,5 cm / 6 7/8"
 massiver Griff, 6 mm,
 solid handle, 6 mm
 mango sólido, 6 mm
 poignée massive, 6 mm
 solida impugnatura, 6 mm

Reinigungsinstrumente

Scalers, periodontology
 Limpiadores de sarro, parodontología
 Instruments à détartrer, parodontologie
 Ablatori di tartaro, parodontologia

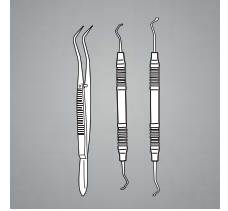

43



Williams-Goldman-Fox
 43-738-02-07
 Grad. 1-2-3-5-7-8-9-10



43-738-04-07
 Fig. CP 11/23
 Grad. 3-6-8-11



43-738-06-07
 Fig. CP 12/23
 Grad. 3-6-9-12

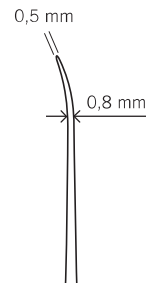

43-738-08-07
 Fig. GF/3
 Grad. 1-2-3-5-7-8-9-10

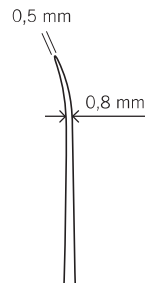

43-738-10-07
 Fig. UM/3
 Grad. 3-6-8

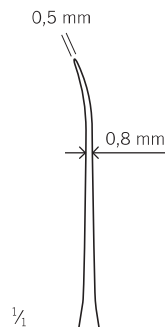
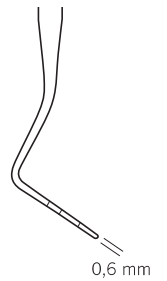
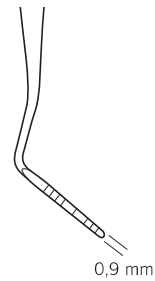
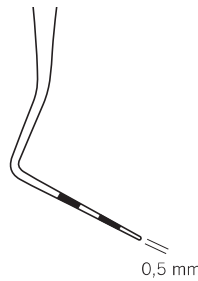
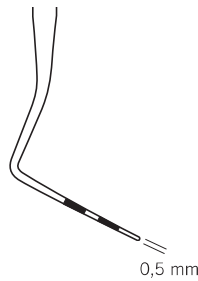

43-738-12-07
 Fig. W/3
 Grad. 1-2-3-5-7-8-9-10



43-738-14-07
 Fig. GF/6
 Grad. 1-2-3-5-7-8-9-10

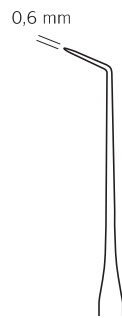

43-738-16-07
 Fig. UM/6
 Grad. 3-6-8

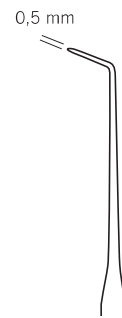

43-738-18-07
 Fig. W/6
 Grad. 1-2-3-5-7-8-9-10



43-738-20-07
 Fig. GF/17
 Grad. 1-2-3-5-7-8-9-10

43-738-02-07 -
 43-738-20-07
 17,5 cm / 6 7/8"
 Hohlgriff, 8 mm
 hollow handle, 8 mm
 mango hueco, 8 mm
 poignée creuse, 8 mm
 manico cavo, 8mm

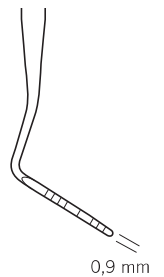
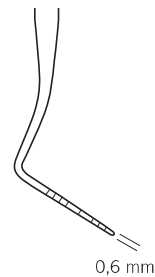
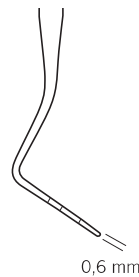
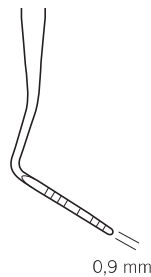
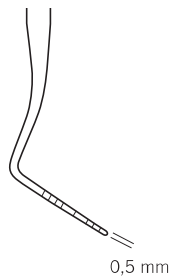

Parodontometer

Periodontal probes
Sondas parodontales
Sondes parodontales
Sonde parodontali



0,5 mm



43-738-22-07

Fig. UM/17

Grad. 3-6-8



0,5 mm

0,5 mm



43-738-24-07

Fig. W/17

Grad. 1-2-3-5-7-8-9-10



0,5 mm

0,9 mm



43-738-26-07

Fig. GF/23

Grad. 1-2-3-5-7-8-9-10



0,6 mm

0,6 mm



43-738-28-07

Fig. UM/23

Grad. 3-6-8



0,5 mm

0,6 mm

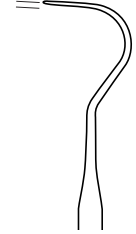

43-738-30-07

Fig. W/23

Grad. 1-2-3-5-7-8-9-10



0,5 mm

43-738-22-07 -
43-738-30-07

17,5 cm / 6 7/8"

Hohlgriff, 8 mm
hollow handle, 8 mm
mango hueco, 8 mm
poignée creuse, 8 mm
manico cavo, 8 mm

Zahnsonden

Explorers
Sondas
Sondes
Sonde

Reinigungsinstrumente

Scalers, periodontology
Limpiadores de sarro, parodontología
Instruments à détartrer, parodontologie
Ablatori di tartaro, parodontologia

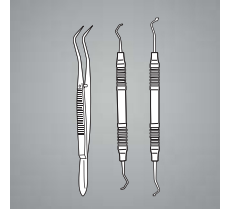

43



Cross
43-348-10-07

17,5 cm / 6 7/8"

Hohlgriff, 8 mm
hollow handle, 8 mm
mango hueco, 8 mm
poignée creuse, 8 mm
manico cavo, 8 mm



Zürich
43-400-02-07

17,5 cm / 6 7/8"

Hohlgriff, 8 mm
hollow handle, 8 mm
mango hueco, 8 mm
poignée creuse, 8 mm
manico cavo, 8 mm

Mikro-Sonde, zum Ertasten des Wurzelkanals von retrograd nach WSR

Micro probe, for retrograde detection of root canal following apicoectomy

Micro sonda, para la detección retrógrada del canal radicular después de la apicectomía

Micro sonde, pour la détection rétrograde du canal de la racine après résection de l'apex

Micro sonda, per la rilevazione retrograda del canale della radice in seguito a interventi di apicectomia

GR = grau
grey
gris
gris
grigio

Y = gelb
yellow
amarillo
jaune
giallo

R = rot
red
rojo
rouge
rosso

G = grün
green
verde
vert
verde

V = violett
violet
violeta
violet
viola

W = weiß
white
blanco
blanc
bianco

B = blau
blue
azur
bleu
blu

C = hellblau
light-blue
azul claro
bleu clair
azzurro

Zahnsonden

Explorers

Sondas

Sondes

Sonde

finoLine

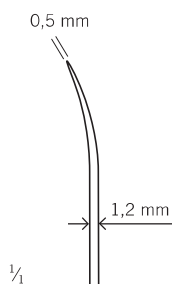

43-400-03-07
Fig. 3



43-400-06-07
Fig. 6

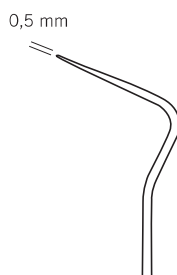

43-400-08-07
Fig. 8 A



43-400-09-07
Fig. 9



43-400-12-07
Fig. 12



43-400-17-07
Fig. 17

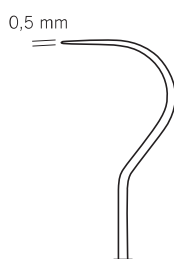

43-400-23-07
Fig. 23

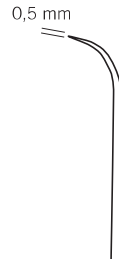

43-400-30-07
Fig. 3A

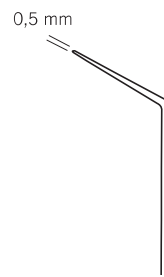

43-400-60-07
Fig. 6XL



White
43-401-12-07
Fig. 12

43-400-03-07 -
43-401-12-07

17,5 cm / 6 7/8"

extra feine Zahnsonde
extra delicate tooth probe
sonda dental extradelicada
sonde dentaire extra fine
sonda dentale superfine

massiver Griff, 6 mm
solid handle, 6 mm
mango sólido, 6 mm
poignée massive, 6 mm
manico cavo, 6 mm

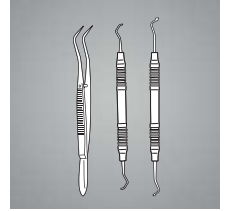

43-402-03-07

Fig. 3

Lokalisierung von Furkationen und Untersuchungen im Interdentalraum

Detection of furcations and for easy entry into interdental spaces

Detección de furcaciones y acceso fácil a los espacios interproximales

Localisation de furcations et examens dans l'espace interdentaire

Localizzazione di furcazioni e per il facile accesso a spazi interdentali

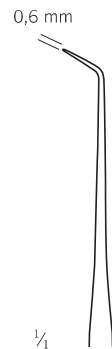

43-402-06-07

Fig. 6

Lokalisierung von Karies, Zahnstein, Wurzelkanälen und Furkationen

Detection of plaque, caries, root canals and furcations

Detección de sarro, caries, canales radiculares y furcaciones

Localisation de caries, de tartre, de canaux de racine et de furcations

Localizzazione di carie, tartaro, canali di radici e forcazioni

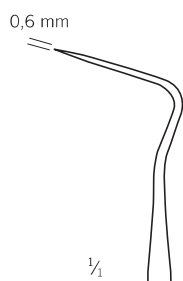

43-402-08-07

Fig. 8A

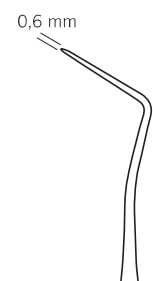

43-402-09-07

Fig. 9



Briault
43-402-11-07

Fig. EXD 11

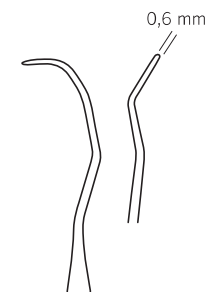

43-402-12-07

Fig. EXD 11-12

43-402-03-07 -
43-402-12-07

17,5 cm / 6 7/8"

massiver Griff, 6 mm

solid handle, 6 mm

mango sólido, 6 mm

poignée massive, 6 mm

manico cavo, 6 mm

Zahnsonden

Explorers
Sondas
Sondes
Sonde

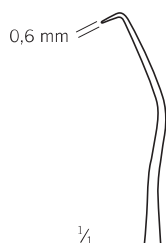

White
43-402-17-07

Fig. 17

Für subgingivale Untersuchung und Approximalkaries

Mainly for sub-gingival examination and approx. caries

Sobre todo para el examen subgingival y caries aproximal

Pour l'examen subgingival et des caries proximales

Principalmente per gli esami subgingivali e carie contigue

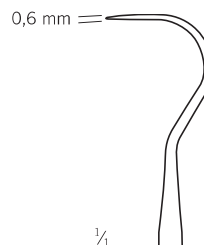

White
43-402-23-07

Fig. 23

Allgemeinuntersuchung, besonders für Schneidezähne

For general examination, especially for incisors

Para el examen general, especialmente de incisivos

Examen général, surtout des incisives

Esame generale, in particolare per gli incisivi

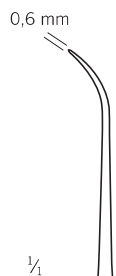

43-402-33-07

Fig. 3A

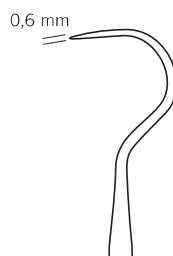

43-402-54-07

Fig. 54

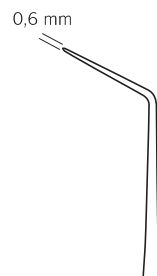

43-402-66-07

Fig. 6XL

Lokalisierung von Karies, Zahnstein, Wurzelkanälen und Furkationen

Detection of plaque, caries, root canals and furcations

Detección de sarro, caries, canales radiculares y furcaciones

Localisation de caries, de tartre, de canaux de racine et de furcations

Localizzazione di carie, tartaro, canali di radici e forcazioni

43-402-17-07 -
43-402-66-07

17,5 cm / 6 7/8"

massiver Griff, 6 mm
solid handle, 6 mm
mango sólido, 6 mm
poignée massive, 6 mm
manico cavo, 6 mm

Reinigungsinstrumente

Scalers, periodontology
 Limpiadores de sarro, parodontología
 Instruments à détartrer, parodontologie
 Ablatori di tartaro, parodontologia

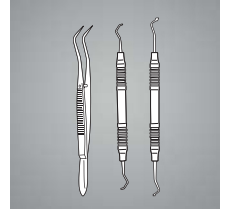

43



43-403-01-07 -
 43-403-23-07
 17,5 cm / 6 7/8"
 Hohlgriff, 8 mm,
 hollow handle, 8 mm
 mango hueco, 8 mm
 poignée creuse, 8 mm
 manico cavo, 8 mm

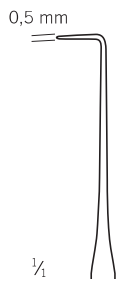

43-403-01-07
 Fig. UT 1/2



43-403-02-07
 Fig. UT 2/2

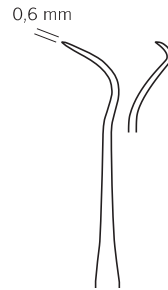

43-403-03-07
 Fig. 3CH/3CH

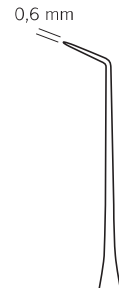

43-403-04-07
 Fig. 6/3

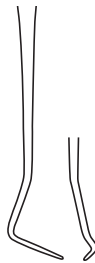

43-403-16-07
 Fig. 16/17



43-403-17-07
 Fig. 17/23



43-403-23-07
 Fig. 23/17A



43-403-06-07
 Fig. 23/6

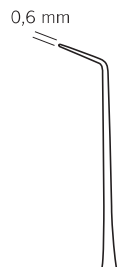

43-403-16-07
 Fig. 16/17



43-403-17-07
 Fig. 17/23

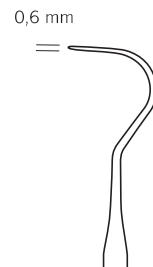

43-403-23-07
 Fig. 23/17A

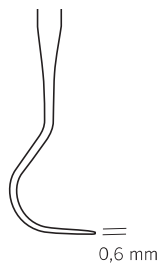

43-403-17-07
 Fig. 17/23

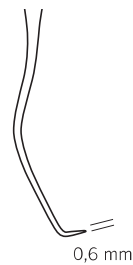

43-403-23-07
 Fig. 23/17A

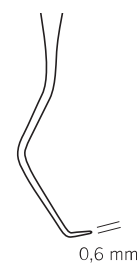

Zahnsonden

Explorers

Sondas

Sondes

Sonde

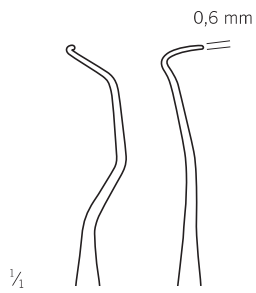

Nabers
43-404-01-07
Fig. 1

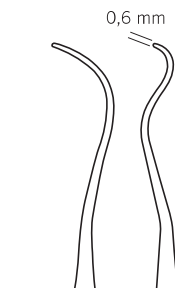

Nabers
43-404-02-07
Fig. 2



43-404-05-07
Fig. 5/6

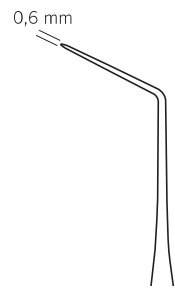

43-404-23-07
Fig. 16/23

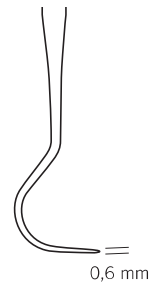
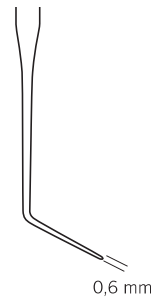
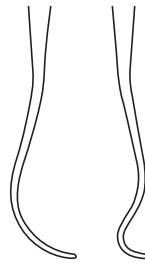
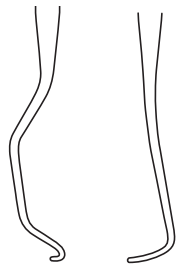

43-404-01-07 -
43-404-23-07

17,5 cm / 6 7/8"

Hohlgriff, 8 mm,
hollow handle, 8 mm
mango hueco, 8 mm
poignée creuse, 8 mm
manico cavo, 8 mm

Zahnsonden-Ansätze

Explorers interchangeable

Sondas intercambiables

Sondes interchangeables

Sonde intercambiabili

Reinigungsinstrumente

Scalers, periodontology

Limpiadores de sarro, parodontología

Instruments à détartrer, parodontologie

Ablatori di tartaro, parodontologia

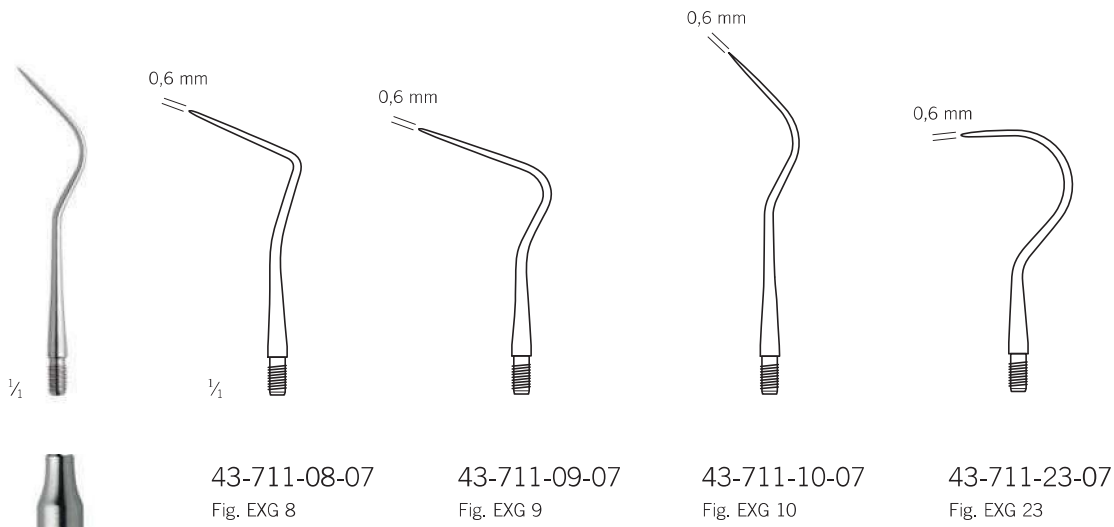
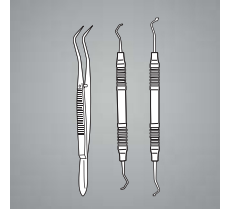

43-711-08-07
Fig. EXG 8

43-711-09-07
Fig. EXG 9

43-711-10-07
Fig. EXG 10

43-711-23-07
Fig. EXG 23

Sondengriffe siehe Seite 244
Probe handles see page 244
Mangos endosondas miren página 244
Poignées endosondes voir page 244
Impugnatori endosonde vedi pagina 244

Exkavatoren

Excavators
Excavadores
Excavateurs
Escavatori

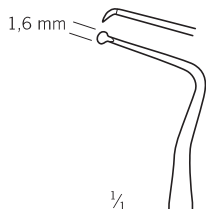

43-482-01-07
Fig. GM 1A

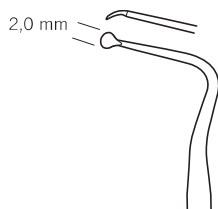

43-482-02-07
Fig. GM 2A



43-484-00-07
Fig. GM 0

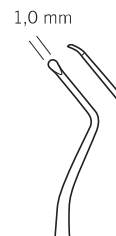

43-484-01-07
Fig. GM 1



43-482-01-07 -
43-486-34-07

17,5 cm / 6 7/8"

Hohlgriff, 8 mm,
hollow handle, 8 mm
mango hueco, 8 mm
poignée creuse, 8 mm
manico cavo, 8 mm

doppelendig
double ended
de doble punta
à extrémité double
a punta doppia

GR = grau
grey
gris
gris
grigio

Y = gelb
yellow
amarillo
jaune
giallo

R = rot
red
rojo
rouge
rosso

G = grün
green
verde
vert
verde

V = violett
violet
violeta
violet
viola

W = weiß
white
blanco
blanc
bianco

B = blau
blue
azur
bleu
blu

C = hellblau
light-blue
azul claro
bleu clair
azzurro

Reinigungsinstrumente

Scalers, periodontology
Limpiadores de sarro, parodontología
Instruments à détartrer, parodontologie
Ablatori di tartaro, parodontologia

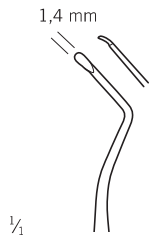
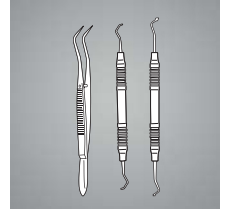

43-484-02-07
Fig. GM 2



43-484-03-07
Fig. GM 3



43-484-04-07
Fig. GM 4

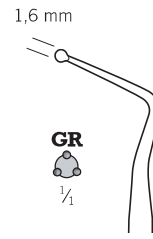

Zürich
43-486-34-07
Ø 1,9 mm



Exkavatoren

Excavators
Excavadores
Excavateurs
Escavatori



| | | | | | | |
|---------------|---------------------------------|---------------------------------|---------------------------------|---------------------------------|---------------------------------|----------------------------|
| | 2,6 mm | 2,0 mm | 2,0 mm | 1,0 mm | 1,2 mm | 0,5 mm |
| $\frac{1}{4}$ | | | | | | |
| | 43-487-00-07 Fig. GM 125/126 | 43-487-02-07 Fig. GM 127/128 | 43-487-04-07 Fig. GM 129/130 | 43-487-06-07 Fig. GM 133/134 | 43-487-08-07 Fig. GM 153/154 | 43-487-10-07 Fig. GM 14 |

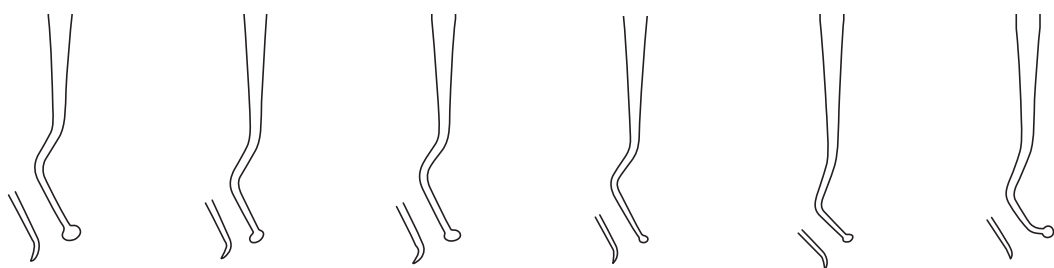

| | | | | | | |
|---------------|-------------------------------|----------------------------|----------------------------|----------------------------|---------------------------|-----------------------------|
| | 1,4 mm | 1,2 mm | 1,5 mm | 3,0 mm | 1,2 mm | 1,2 mm |
| $\frac{1}{4}$ | | | | | | |
| | 43-487-12-07 Fig. GM 38/39 | 43-487-14-07 Fig. GM E1 | 43-487-16-07 Fig. GM E2 | 43-487-18-07 Fig. GM E3 | 43-487-20-07 Fig. GM 6 | 43-487-22-07 Fig. GM 17S |

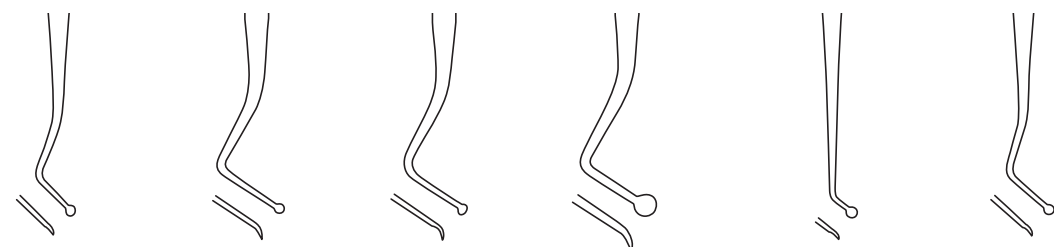

$\frac{1}{4}$
43-487-00-07 -
43-487-44-07
17,5 cm / 6 $\frac{7}{8}$ "
Hohlgriff, 8 mm
hollow handle, 8 mm
mango hueco, 8 mm
poignée creuse, 8 mm
manico cavo, 8 mm
doppelendig
double ended
de doble punta
à extrémité double
a punta doppia

Reinigungsinstrumente

Scalers, periodontology
Limpiadores de sarro, parodontología
Instruments à détartrer, parodontologie
Ablatori di tartaro, parodontologia

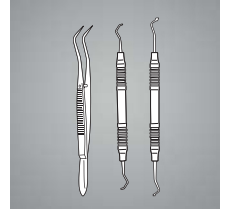

43

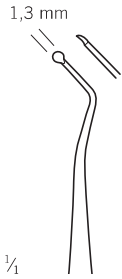

43-487-24-07
Fig. GM 17

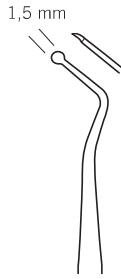

43-487-26-07
Fig. GM 18



43-487-28-07
Fig. GM 19



43-487-30-07
Fig. GM 17W



43-487-32-07
Fig. GM 18W



43-487-34-07
Fig. GM 19W



43-487-35-07
Fig. GM 61/62



43-487-36-07
Fig. GM 63/64



43-487-38-07
Fig. GM 65/66

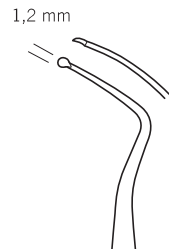

43-487-40-07
Fig. GM 31L

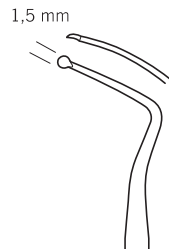

43-487-42-07
Fig. GM 32L

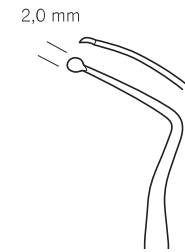

43-487-44-07
Fig. GM 33L

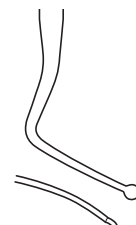
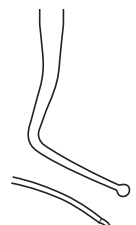

Schmelzmeißel

Enamel chisels
 Cinceles para esmalte
 Ciseaux à émail
 Tagliasmalto



43-493-01-07
 Fig. 1

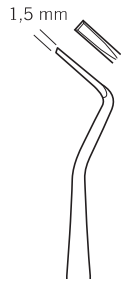

43-493-02-07
 Fig. 2



43-493-26-07
 Fig. 26

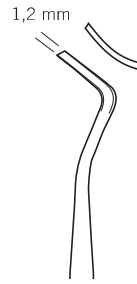

43-493-27-07
 Fig. 27



43-493-28-07
 Fig. 28



43-493-29-07
 Fig. 29

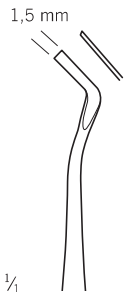

43-493-52-07
 Fig. 51/52



43-493-54-07
 Fig. 53/54



43-493-64-07
 Fig. 63/64

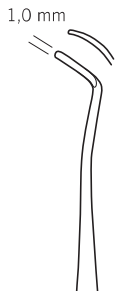

43-493-66-07
 Fig. 65/66



43-493-78-07
 Fig. 77/78



43-493-80-07
 Fig. 79/80



1/4

Black
 43-493-01-07 -
 43-493-80-07

17,5 cm / 6 7/8"

massiver Griff, 6 mm
 solid handle, 6 mm
 mango sólido, 6 mm
 poignée massive, 6 mm
 solida impugnatura, 6 mm

doppelendig
 double ended
 de doble punta
 à extrémité double
 a punta doppia

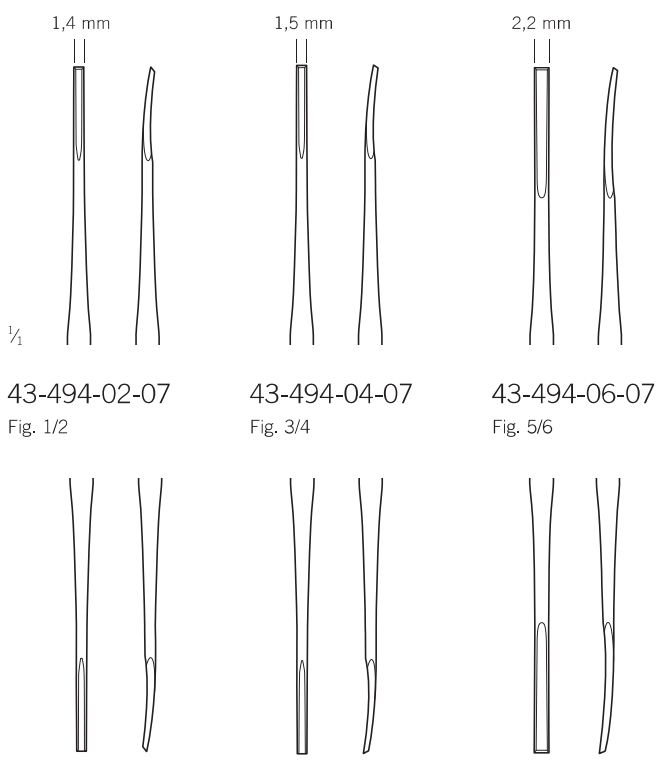
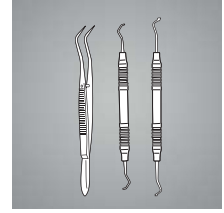

1/4

Wedelstaedt
43-494-02-07 -
43-494-06-07
17,5 cm / 6 7/8"
massiver Griff, 6 mm
solid handle, 6 mm
mango sólido, 6 mm
poignée massive, 6 mm
solida impugnatura, 6 mm
doppelendig
double ended
de doble punta
à extrémité double
a punta doppia

Nervkanal-Instrumente

Root canal instruments
Instrumentos para canales
Instruments à canaux
Strumenti per trattamenti canalari

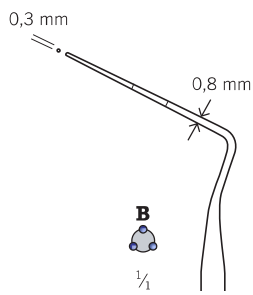

Zürich
43-500-31-07
Fig. 30/40

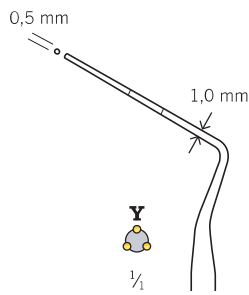

Zürich
43-500-51-07
Fig. 50/90

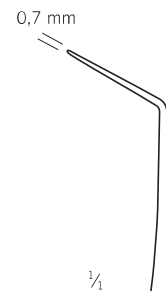

Stewart
43-504-01-07

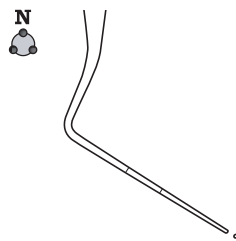

Plugger
Plugger
Obturador
Obturateur
Otturatore

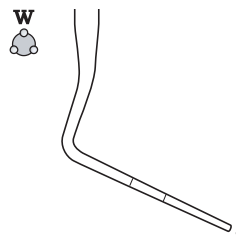

Plugger
Plugger
Obturador
Obturateur
Otturatore



Endo-Sonde
Endo probe
Endosonda
Endosonde
Endosonda

1/1

43-500-31-07 -
43-504-01-07

17,5 cm / 6 7/8"

Hohlgriff, 8 mm
hollow handle, 8 mm
mango hueco, 8 mm
poignée creuse, 8 mm
manico cavo, 8 mm

doppelendig
double ended
de doble punta
à extrémité double
a punta doppia



GR = grau
grey
gris
gris
grigio



Y = gelb
yellow
amarillo
jaune
giallo



R = rot
red
rojo
rouge
rosso



G = grün
green
verde
vert
verde



V = violett
violet
violeta
violet
viola



W = weiß
white
blanco
blanc
bianco



B = blau
blue
azur
bleu
blu



N = schwarz
black
negro
noir
nero

Reinigungsinstrumente

Scalers, periodontology
Limpiadores de sarro, parodontología
Instruments à détartrer, parodontologie
Ablatori di tartaro, parodontologia

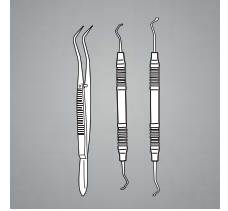

43

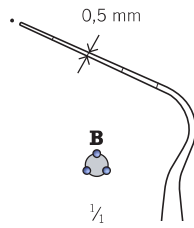

43-505-03-07
Fig. 30

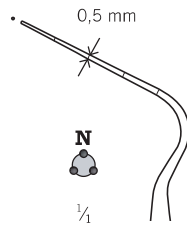

43-505-04-07
Fig. 40

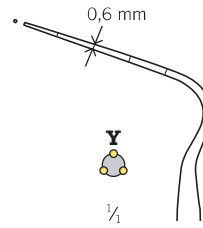

43-505-05-07
Fig. 50

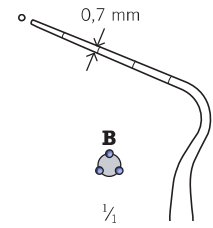

43-505-06-07
Fig. 60

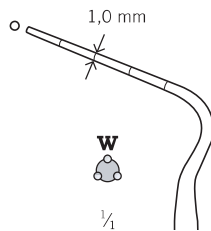

Plugger
Plugger
Obturador
Obturateur
Otturatore

43-505-09-07
Fig. 90

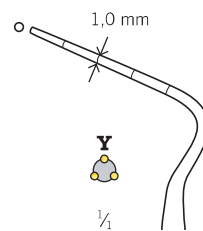

43-505-10-07
Fig. 100

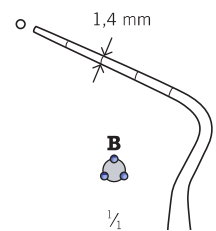

43-505-12-07
Fig. 120

1/4

43-505-03-07 -
43-505-12-07

17,5 cm / 6 7/8"

massiver Griff, 6 mm
solid handle, 6 mm
mango sólido, 6 mm
poignée massive, 6 mm
solida impugnatura, 6 mm

einendig
single ended
de una sola punta
à une extrémité
a una sola punta

Nervkanal-Instrumente

Root canal instruments
Instrumentos para canales
Instruments à canaux
Strumenti per trattamenti canalari



43-506-01-07 -
43-507-06-07
16 cm / 6 1/8"
massiver Griff, 6 mm
solid handle, 6 mm
mango sólido, 6 mm
poignée massive, 6 mm
solida impugnatura, 6 mm
einendigt
single ended
de una sola punta
à une extrémité
a una sola punta

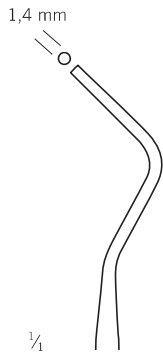

43-506-01-07
Fig. 1



43-506-02-07
Fig. 2



43-506-03-07
Fig. 3

Plugger
Plugger
Obturador
Obturateur
Otturatore

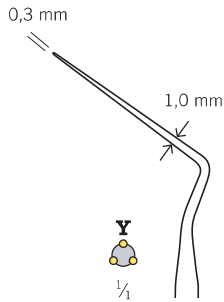

43-507-02-07
Fig. 20

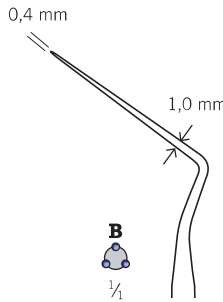

43-507-03-07
Fig. 30

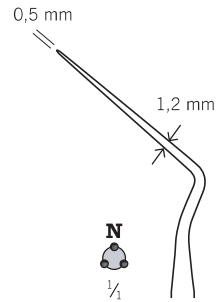

43-507-04-07
Fig. 40

Spreader
Spreader
Extendedor
Etendeur
Estensore

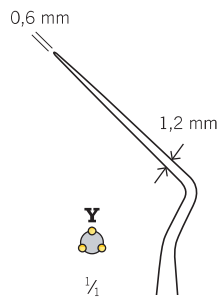

43-507-05-07
Fig. 50

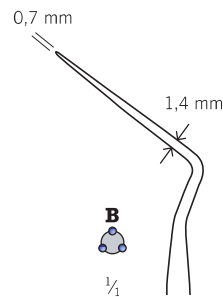

43-507-06-07
Fig. 60

Spreader
Spreader
Extendedor
Etendeur
Estensore

GR = grau
grey
gris
gris
grigio

Y = gelb
yellow
amarillo
jaune
giallo

R = rot
red
rojo
rouge
rosso

G = grün
green
verde
vert
verde

V = violett
violet
violeta
violet
viola

W = weiß
white
blanco
blanc
bianco

B = blau
blue
azur
bleu
blu

N = schwarz
black
negro
noir
nero

Gingivektomiemesser

Gingivectomy knives

Bisturías para la gingivectomía

Bistouris pour la gingivectomie

Bisturie per gengivectomia

Parodontologie

Periodontology

Parodontología

Parodontologie

Parodontologia

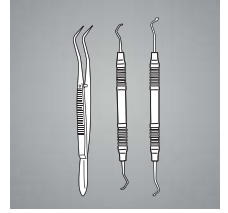

1/4

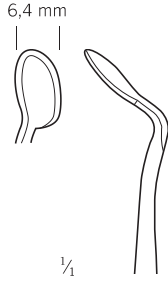

43-326-37-07

Fig. 7

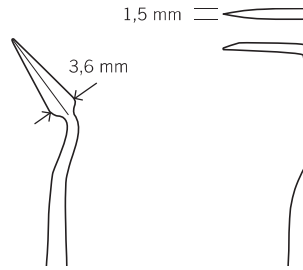

43-326-38-07

Fig. 8



43-326-39-07

Fig. 9



43-326-40-07

Fig. 10



43-326-41-07

Fig. 11

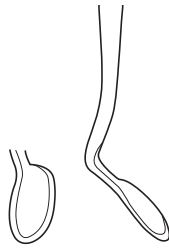

43-326-37-07 -
43-326-41-07

17,5 cm / 6 7/8"

massiver Griff, 6 mm

solid handle, 6 mm

mango sólido, 6 mm

poignée massive, 6 mm

solida impugnatura, 6 mm

doppelendig

double ended

de doble punta

à extrémité double

a punta doppia

43

Gingivektomiemesser

Gingivectomy knives

Bisturíes para la gingivectomía

Bistouris pour la gingivectomie

Bisturie per gengivectomia

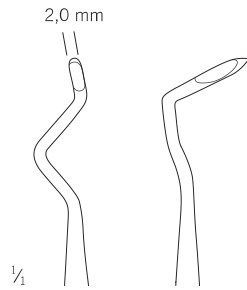

38-050-03-07

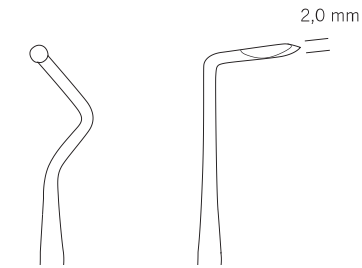

38-050-04-07

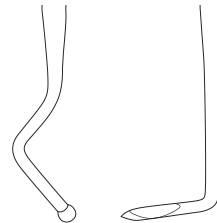
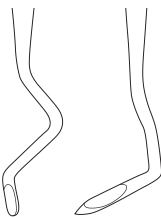

Allen-Iglhaut
38-050-03-07 -
38-050-04-07

16 cm / 6 1/8"

Hohlgriff, 10 mm
hollow handle, 10 mm
mango hueco, 10 mm
poignée creuse, 10 mm
manico cavo, 10 mm

doppelendig
double ended
de doble punta
à extrémité double
a punta doppia

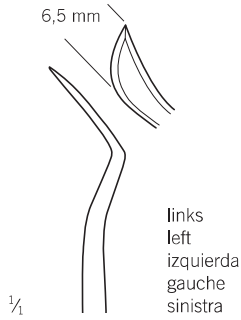
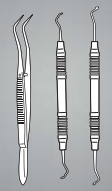

Kirkland
43-331-51-07

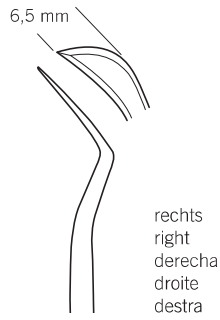

Kirkland
43-331-61-07

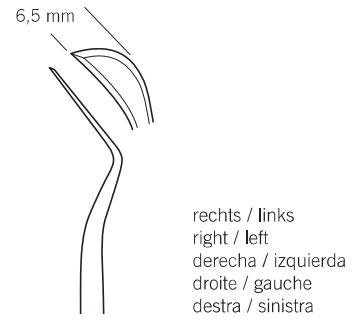

Kirkland
43-332-61-07

Für Gingivektomie und Rekonturierung de
Sehr wirksam im retromolaren Bereich

For gingivectomy or gingivoplastic surgery.
Very effective in retro molar region

Para la gingivectomía o cirugía gingivoplástica.
Muy eficaz en la región retromolar

Pour gingivectomie et gingivoplastie chirurgicale.
Très efficace dans la région rétromolaire

Per la gengivectomia e la chirurgia gengivoplastica.
Molto efficace nella regione retromolare



Orban
43-333-01-07

Fig. 1

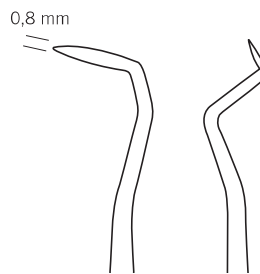

Orban
43-333-02-07

Fig. 2

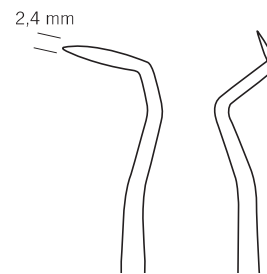

Orban
43-333-12-07

Fig. 1/2

Mit kontragewinkeltem Schaft, speziell für posteriore Anwendung
sowie für das Exzisieren von interproximalem Gewebe bei Gingivektomie

Counter angled shank, especially suitable for excision of
interproximal tissue in gingivectomy

Vástago contraangular, especialmente idóneo para la extracción del
tejido interproximal en gingivectomía

Avec tige contre coudée, spéciale pour application postérieure
et excision de tissus interproximaux en gingivectomie

Con stelo controangolato, speciale per l'asportazione di tessuto
interprossimale in gengivectomia



43-331-51-07 -
43-333-12-07

16 cm / 6 1/8"

massiver Griff, 6 mm
solid handle, 6 mm
mango sólido, 6 mm
poignée massive, 6 mm
solida impugnatura, 6 mm

einendig
single ended
de una sola punta
à une extrémité
a una sola punta